

# Probes and sensors for coordinate measuring machines

High performance for any application





HEXAGON

HEXAGON

# CMM probes and sensors

## A solution for any application

When it comes to maintaining quality and driving inspection efficiency, choosing the right probe or combination of probes and sensors is crucial.

The wrong probe or sensor can cause production bottlenecks, rework and scrap. The right probe or sensor can drive throughput, maintain competitiveness, and enhance profitability. This document is designed to help manufacturers find the right probing system.

At the very minimum, any coordinate measuring machine (CMM) probing system should contribute to manufacturing productivity with robust performance and reliability. But since every application has different demands, manufacturers should be given the choice of a variety of probes and sensors primed for different measuring tasks.

Whether the job demands high accuracy, speed, flexibility, or a combination of the three, Hexagon Manufacturing Intelligence offers a comprehensive range of probes, probe heads, styli changers and accessories for CMMs to ensure manufacturers have the optimum solutions for their application.

Offering high durability for operation in industrial environments, Hexagon's probe and sensor systems enable users to enhance quality with:

- State-of-the-art technology
- Precise and reliable operation
- Maximum application flexibility and outstanding usability
- Quick and effective interchange of multiple sensors on one machine
- Extended modularity to configure optimised inspection systems according to productivity requirements

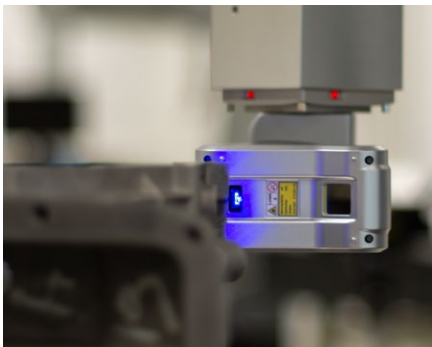

Non-contact sensors enable fast capture of workpiece data and greater application flexibility.



Innovative technologies enable best-in-class solutions for even the most challenging applications.



Thanks to the wide portfolio of accessories, sensors can be easily adapted to changing applications.



# Probe heads

## Increasing accessibility

Combined with a sensor, the probe head forms the heart of the CMM. Efficient inspection and data capture relies on using the right probe head, as this significantly influences the level of measuring speed and flexibility that can be achieved. Hexagon provides a variety of different types of probe heads to ensure manufactures have the solutions most suited to their application needs.

### **Manual Probe Heads**

Highly reliable and cost-effective, manual probe heads for touch trigger probes provide excellent basic capabilities. These heads enable the probes to be easily positioned to the required measurement points.

### **Automatic Indexing Probe Heads**

Enabling greater measuring versatility, these fully motorised probe heads are characterised by high speed operation and repeatability. They are equipped with a kinematic joint for multisensor capability, enabling use of tactile probes and laser scanners on one machine.

### **Continuous Probe Heads**

High-performance continuous wrist probe heads offer maximum flexibility, with virtually infinite angular positioning to capture parts. Combining high speed motion and compatibility with a range of probe types, these probe heads enable point-to-point measuring and scanning.

### **Heavy Duty Probe Heads**

Particularly suited for use with large or heavy probes, the Heavy Duty Probe Heads capture highly accurate measurements while carrying sensors further away from the machine ram than other probe heads.

# Tactile probes

## Highest precision

Enabling very precise and repeatable 3D measurements, Hexagon's tactile probes are characterised by their long lifetime, high accuracy, ease of use and excellent access to difficult to reach measuring points.

Hexagon offers a wide range of scanning and touch trigger probes to ensure users have the right contact probing solution to meet uncertainty and repeatability requirements, as well as drive productivity with varying degrees of speed and accuracy.

### Scanning Probes

Scanning probes combine high precision and speed. With these probes, users can perform fast and accurate contour and form measurements as well as all standard measurements including discrete scanning, self-centring measuring and continuous high-speed scanning.

### Touch Trigger Probes

These probes perform fast and repeatable 3D point measurements. Thanks to different trigger forces and the compact design, touch trigger probes can be used very flexibly while being cost effective and easy to use.

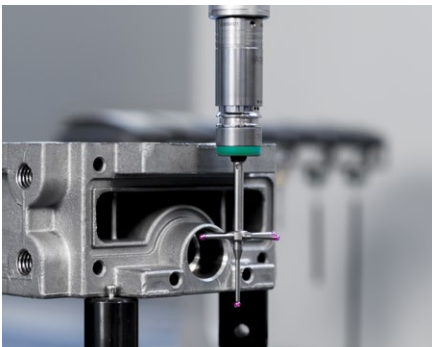

HP-THD touch trigger probe - enables fast and highly accurate 3D point measurements. See page 20.



HP-S-X5 scanning probe - for highly accurate, continuous scanning measurements. See page 26.

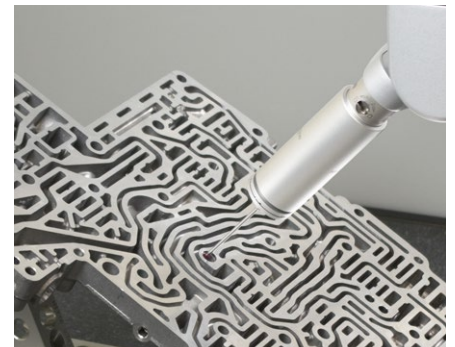

HP-S-X1S scanning probe - for fast and flexible scanning measurements. See page 24.

# Non-contact sensors

## Fast and versatile

Non-contact sensors greatly enhance a CMM's inspection capabilities. When measuring complex parts with difficult-to-access features or sensitive surfaces, non-contact sensors provide essential flexibility. Likewise, where quick measurements have to be done, non-contact sensors provide unparalleled speed.

### Laser Scanning Sensors

Laser scanning sensors allow rapid collection of high density point cloud data for inspection or reverse engineering. Hexagon laser scanning technologies deliver highest quality data under all environmental conditions, by automatically suppressing outliers caused by reflections or ambient light.

### Vision Sensors

The high-resolution camera sensors give measurement performance that tactile probes literally can't touch. A camera mounted directly on an automatic indexing probe head, vision sensors can be rotated in any position to inspect 2D features. This setup effectively replicates the flexibility and part access that can be achieved when using a vision system with a rotary table.

### Optical Sensors

Hexagon's HP-O scanning technology is based on frequency-modulated interferometric optical distance measurement. It combines a high scanning speed with increased measurement range, providing an alternative for high-precision tactile measurements when speed is important, parts are difficult to access with tactile probes or when parts may deform or be damaged by tactile probing.



HP-L-5.8 laser scanning sensor - affordable sensor for creation of point clouds on CMMs. See page 29.



HP-L-10.6 laser scanning sensor - flexible and adjustable sensor for creation of point clouds on CMMs. See page 28.



HP-O Flex sensor - highly accurate, fast and flexible non-contact measurements on CMMs. See page 31.

# Racks and sensor accessories

## Pushing flexibility further

Hexagon's ranges of changer racks and sensor accessories allow users to adjust measurement capabilities for all kinds of applications, enhancing efficiency and flexibility.

### Racks

Hexagon's changer racks perform fast and repeatable exchanges of probe, extension and stylus configurations on the CMM probe head. These racks enable automatic multisensor utilisation within a single part program, helping users efficiently adapt to different workpiece requirements and reduce cycle times.

### Sensor accessories

Challenging measurement applications often require more hardware features than what is possible with a standard configuration. With Hexagon's wide range of sensor accessories, such as extensions and adapters, it is possible to reach even the most difficult positions.



HR-R probe changer rack - enables quick exchange of TKJ sensors during the measurement program. See page 33.



HR-MP probe module changer rack - exchange of HP-TM or HP-THD modules during part programs. See page 34.



HR-R probe changer rack - also compatible with long extensions and the heavy duty probe heads. See page 33.

# Styli and other accessories

## Excellent products for outstanding measurement results

To give production more leeway in to utilise tolerances, it is essential that manufacturing measurement technology and quality assurance systems use methods with the lowest possible measurement uncertainty. Measurement uncertainty is often determined the complete measuring system, including parts like stylus configurations or fixture solutions.

To meet maximum precision and quality requirements, all Hexagon Manufacturing Intelligence accessories are manufactured to the highest standards. There are available components for all kinds of coordinate measuring machines (CMMs), 3D laser trackers, portable measuring arms and probes for machine tools.

From fixtures to machine housings, from styli to cleaning supplies, Hexagon offers the most suitable accessories for even the most challenging applications.

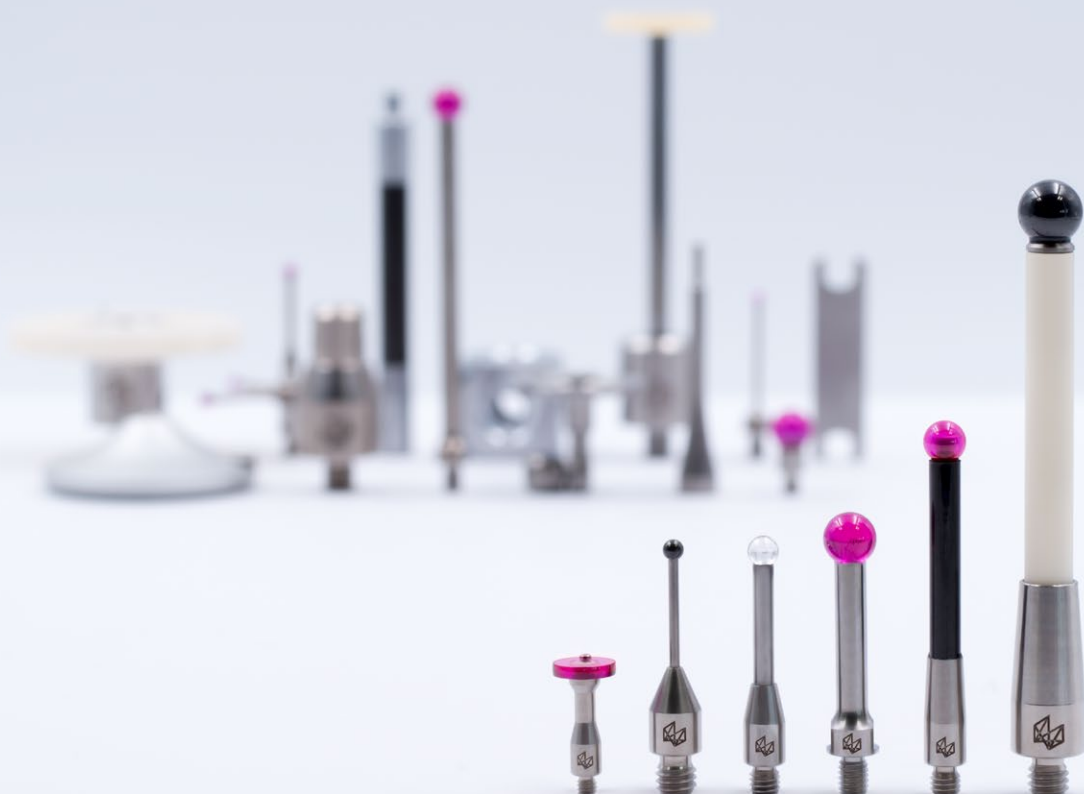







HH-AS8-T2.5

NOTICE  
Laser must be off before connecting or disconnecting from CMA

⚠  
⏻

HP-L-5.8

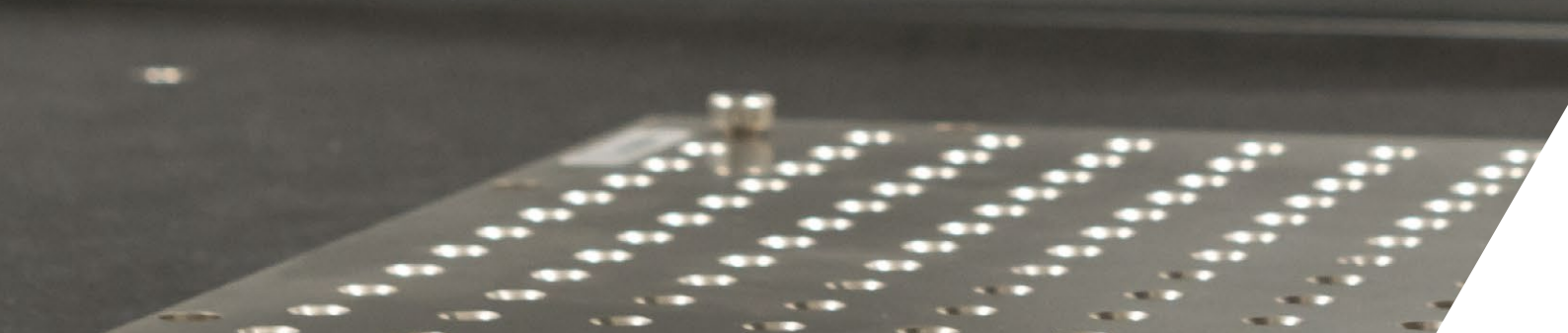

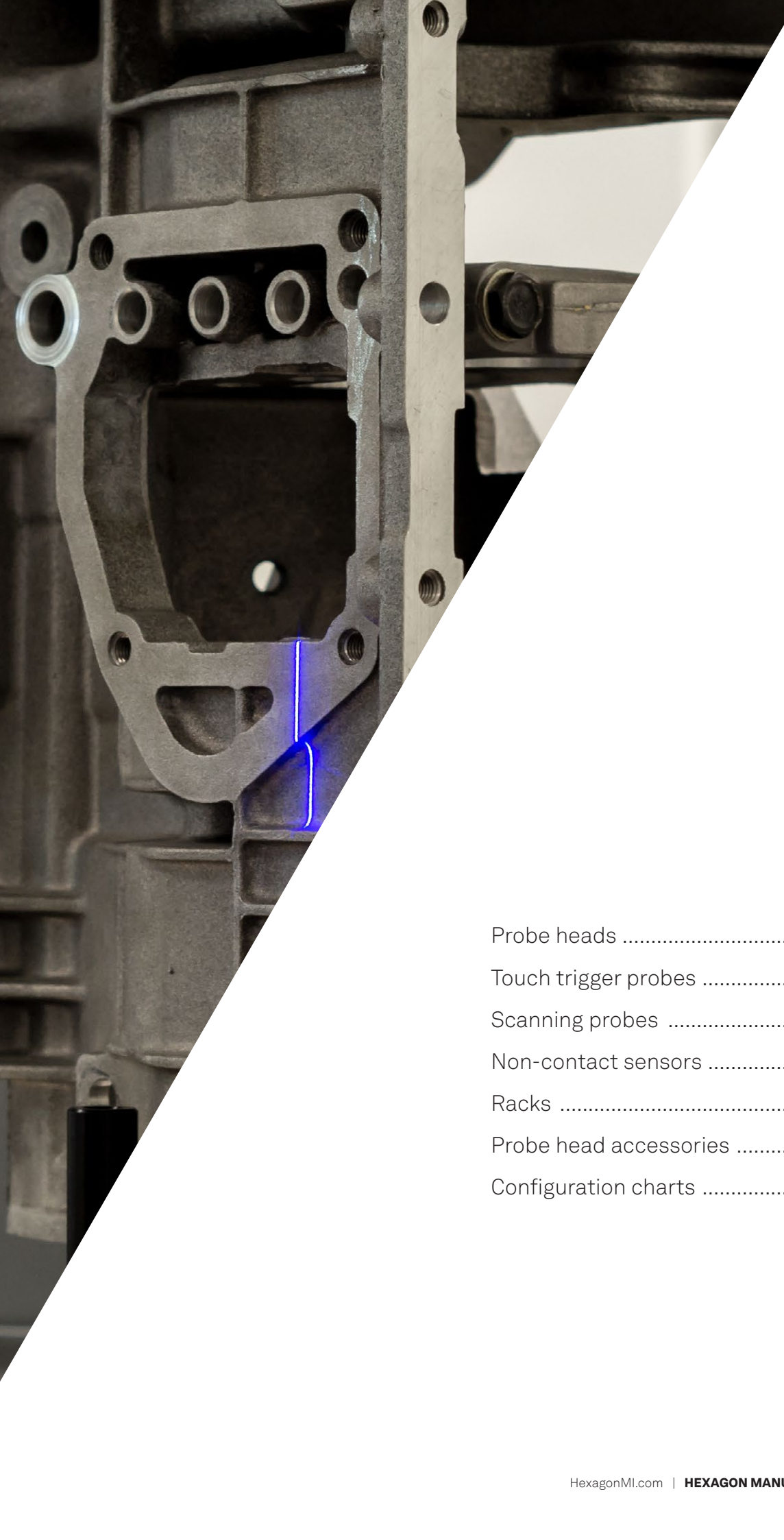

	Page
Probe heads .....	12
Touch trigger probes .....	20
Scanning probes .....	24
Non-contact sensors .....	28
Racks .....	32
Probe head accessories .....	38
Configuration charts .....	42

## Manual probe head

HH-T



HH-T is a manually adjustable probe head that can be rotated into an infinite number of non-repeatable positions. Highly flexible yet cost-effective, the HH-T is the ideal tool for small and entry-level machines. Trigger force is manually adjustable to give optimal probing performance with many stylus configurations.

HH-T		
<b>Manual probe head</b>	Part No. *	03939020
	Probe repeatability 1D (2 Sigma)**	0.75 µm
	Adjustable trigger force	0.1 to 0.3 N
	Overtravel	X/Y = ± 20°, Z = + 6 mm
	Measuring directions	± X, ± Y, + Z

\* For information about available sets, please see page 46

\*\* Test conditions: Stylus length 21 mm, force setting 0.12 N, touch speed 8 mm/sec.

## Manual probe heads

HH-MI | HH-MI-M

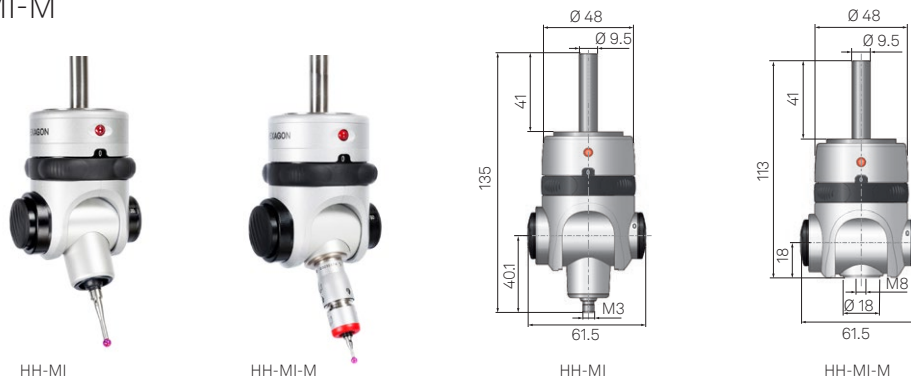

These manually indexable probe heads are capable of indexing in 15° increments and can achieve 168 unique positions without the need for requalification. The heads can be easily locked, unlocked and rotated with one hand.

The HH-MI features an integrated, high-precision touch trigger probe, which can be manually adjusted to allow for a wide range of stylus combinations.

The HH-MI-M features an M8 threaded connection, which enables users to mount a touch trigger probe on the head. When combined with a HP-TM touch trigger probe, probe modules can be exchanged with the HR-MP probe module changer to give the flexibility of an automatic stylus change without the need for requalification.

	HH-MI	HH-MI-M	
<b>Manual probe heads</b>	Part No. *	03939030	03939031
	Angular rotation	A: 0° - 90°, B: ± 180°	A: 0° - 90°, B: ± 180°
	Increments	15°	15°
	Total number of positions	168	168
	Position repeatability	1.5 µm	1.5 µm
	Extensions	-	M8/M8, max. length 50mm
	Probe repeatability 1D (2 Sigma)**	0.35 µm	-
	Adjustable trigger force	0.1 to 0.3 N	-
	Overtravel	X/Y = ± 20°, Z = + 6 mm	-
	Measuring directions	± X, ± Y, + Z	-
Axis clamping	Manual, by two buttons on the probe head	Manual, by two buttons on the probe head	

\* For information about available sets and accessories, please see page 46

\*\* Test conditions: Stylus length 21 mm, force setting 0.12 N, touch speed 8 mm/sec.

## Automatic 5° probe heads

HH-AS6-T5 | HH-AS6-M5 | HH-AS8-T5 | HH-AS8-M5 | HH-A-T5 | HH-A-M5

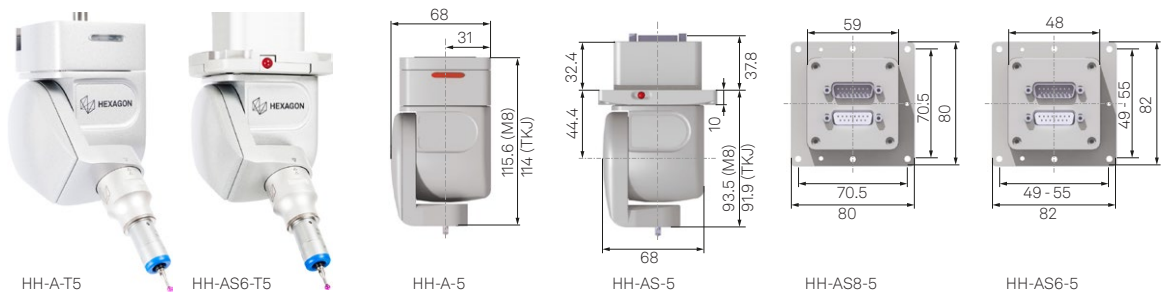

Offering high speed operation and high rotational torque, these probe heads are capable of indexing in steps of 5° and can achieve 3 024 unique positions.

The probe heads can either be mounted on the CMM with a shank or flange (HH-A version) or directly into the ram of the machine (HH-AS version for 80 mm or 65 mm rams).

The HH-A-M5 and HH-AS-M5 probe heads are fitted with an M8 threaded connection so users can leverage a touch trigger probe. The HH-A-T5 and HH-AS-T5 probe heads are fitted with a kinematic joint (TKJ), which makes them compatible with a wide range of Hexagon TKJ sensors such as scanning probes or laser scanners.

	HH-AS6-T5 TKJ 5°	HH-AS6-M5 M8 5°	HH-AS8-T5 TKJ 5°	HH-AS8-M5 M8 5°	HH-A-T5 TKJ 5°	HH-A-M5 M8 5°
Part no. *	03939260	03939280	03939270	03939290	03939450	03939400
Indexing angle	5°	5°	5°	5°	5°	5°
A axis	+ 90° to -115°	+ 90° to -115°	+ 90° to -115°	+ 90° to -115°	+ 90° to -115°	+ 90° to -115°
B axis	± 180°	± 180°	± 180°	± 180°	± 180°	± 180°
Total number of positions	3 024	3 024	3 024	3 024	3 024	3 024
Rotation speed	90° in 2 sec.	90° in 2 sec.	90° in 2 sec.	90° in 2 sec.	90° in 2 sec.	90° in 2 sec.
Positioning repeatability	< 0.5 µm at 100 mm from the centre of A axis rotation	< 0.5 µm at 100 mm from the centre of A axis rotation	< 0.5 µm at 100 mm from the centre of A axis rotation	< 0.5 µm at 100 mm from the centre of A axis rotation	< 0.5 µm at 100 mm from the centre of A axis rotation	< 0.5 µm at 100 mm from the centre of A axis rotation
Max. recommended drive torque	0.6 Nm	0.6 Nm	0.6 Nm	0.6 Nm	0.6 Nm	0.6 Nm
Max. extension length	300 mm	300 mm	300 mm	300 mm	300 mm	300 mm
Weight	880 g	880 g	900 g	900 g	780g	780g
Head mounting	65 mm ram	65 mm ram	80 mm ram	80 mm ram	Shank/flange	Shank/flange
Head controller	HH-C-V2.1 / HH-CA-V2.0 (with HR-R probe changer rack)	HH-C-V2.1 / HH-CA-V2.0 (with HR-R probe changer rack)	HH-C-V2.1 / HH-CA-V2.0 (with HR-R probe changer rack)	HH-C-V2.1 / HH-CA-V2.0 (with HR-R probe changer rack)	HH-C-V2.1 / HH-CA-V2.0 (with HR-R probe changer rack)	HH-C-V2.1 / HH-CA-V2.0 (with HR-R probe changer rack)
Probe mounting	TKJ (multiwire)	M8 thread (2 wires)	TKJ (multiwire)	M8 thread (2 wires)	TKJ (multiwire)	M8 thread (2 wires)

\* For information about available sets and adapters, please see pages 46 - 47

## Automatic 7.5° probe heads

HH-AS8-T7.5 | HH-AS8-M7.5 | HH-A-T7.5 | HH-A-M7.5

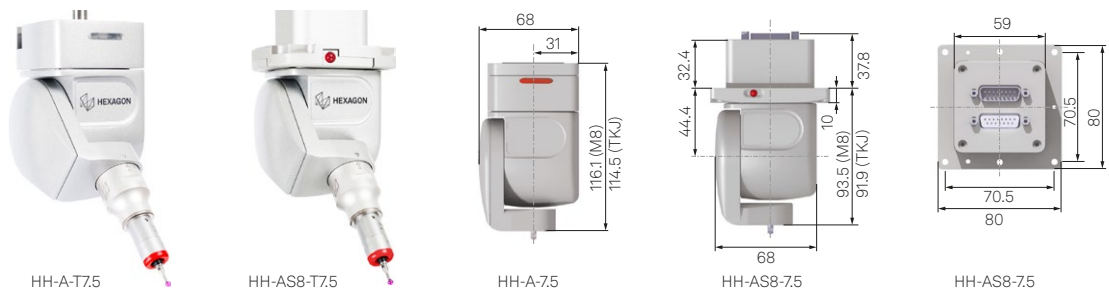

The HH-A-M7.5 and HH-AS-M7.5 motorised indexable probe heads feature an M8 threaded connection to enable the mounting of a touch trigger probe. The HH-A-T7.5 and HH-AS8-T7.5 probe heads are fitted with a kinematic joint (TKJ), which enables multisensor capabilities.

	HH-AS8-T7.5 TKJ 7.5°	HH-AS8-M7.5 M8 7.5°	HH-A-T7.5 TKJ 7.5°	HH-A-M7.5 M8 7.5°
Part no. *	03939362	03939363	03939360	03939361
Indexing angle	7.5°	7.5°	7.5°	7.5°
A axis	+ 105° to - 0°	+ 105° to - 0°	+ 105° to - 0°	+ 105° to - 0°
B axis	± 180°	± 180°	± 180°	± 180°
Total number of positions	720	720	720	720
Rotation speed	90° in 2 sec.	90° in 2 sec.	90° in 2 sec.	90° in 2 sec.
Positioning repeatability	< 0.5 µm at 100 mm from the centre of A axis rotation	< 0.5 µm at 100 mm from the centre of A axis rotation	< 0.5 µm at 100 mm from the centre of A axis rotation	< 0.5 µm at 100 mm from the centre of A axis rotation
Max. recommended drive torque	0.6 Nm	0.6 Nm	0.6 Nm	0.6 Nm
Max. extension length	300 mm	300 mm	300 mm	300 mm
Weight	900 g	900 g	800g	800g
Head mounting	80 mm ram	80 mm ram	Shank/flange	Shank/flange
Head controller	HH-C-V2.1 / HH-CA-V2.0 (with HR-R probe changer rack)	HH-C-V2.1 / HH-CA-V2.0 (with HR-R probe changer rack)	HH-C-V2.1 / HH-CA-V2.0 (with HR-R probe changer rack)	HH-C-V2.1 / HH-CA-V2.0 (with HR-R probe changer rack)
Probe mounting	TKJ (multiwire)	M8 thread (2 wires)	TKJ (multiwire)	M8 thread (2 wires)

\* For information about available sets and adapters, please see pages 46 - 47

## Automatic 2.5° probe heads

HH-A-T2.5 | HH-AS8-T2.5

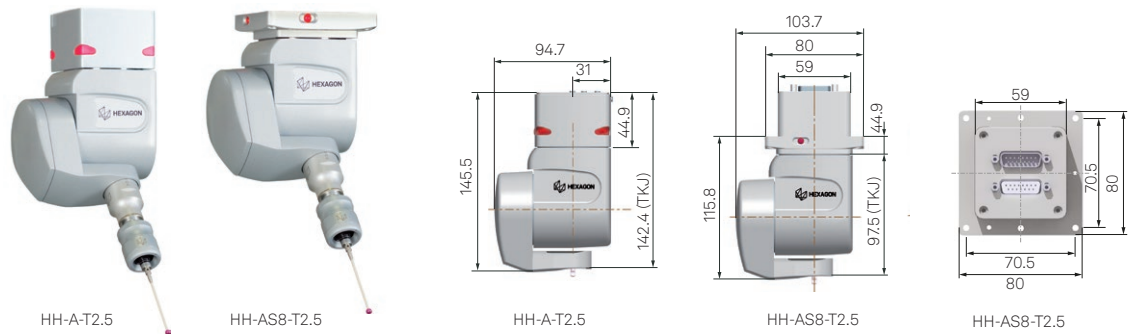

Thanks to a sophisticated drive system, these probe heads feature a large number of indexable positions and very high rotational torque.

The HH-A-T2.5 range is capable of indexing in 2.5° increments and can achieve 12 240 unique positions. They feature an embedded controller, capacitive crash protection and positioning by use of a hirth gear.

The probe heads can either be mounted on the CMM with a shank or flange (HH-A version) or directly into the ram of the machine (HH-AS version for 80 mm rams).

The probe heads' TKJ can be connected to a multiwire to enable full multisensor capabilities.

	HH-A-T2.5 TKJ 2.5°	HH-AS8-T2.5 TKJ 2.5°
Part no. *	03939420	03939422
Indexing angle	2.5°	2.5°
A axis	± 105°	± 105°
B axis	± 180°	± 180°
Total number of positions	12 240	12 240
Rotation speed	90° in 2.5 s	90° in 2.5 s
Positioning repeatability	< 0.5 µm at 100mm from the centre of A axis rotation	< 0.5 µm at 100mm from the centre of A axis rotation
Max. recommended drive torque	1.4 Nm	1.4 Nm
Max. extension length	450 mm	450 mm
Weight	1 600 g	1 650 g
Head mounting	Shank/flange	80 mm ram
Head controller	HH-C-V2.1 / HH-CA-V2.0 (with HR-R probe changer rack)	HH-C-V2.1 / HH-CA-V2.0 (with HR-R probe changer rack)
Probe mounting	TKJ (multiwire)	TKJ (multiwire)

\* For information about available sets and adapters, please see pages 46 - 47



## Automatic 2.5° HDKJ probe heads

HH-A-H2.5 | HH-AS8-H2.5

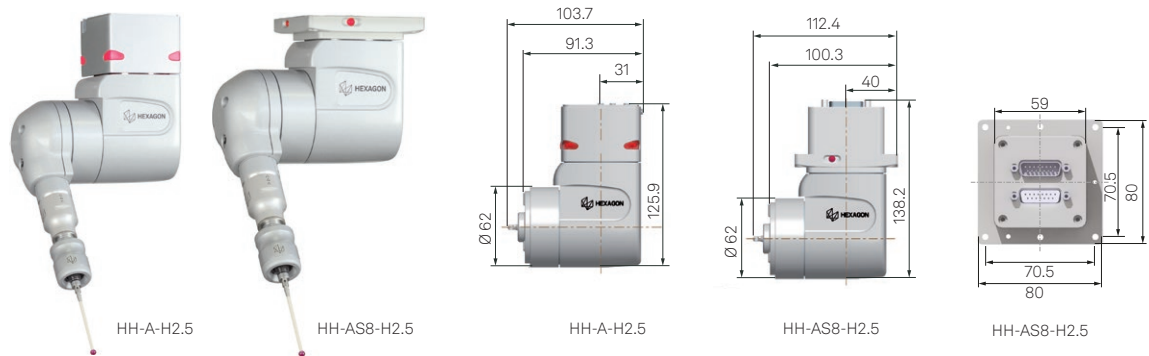

Offering the highest level of measuring flexibility, these probe heads are capable of indexing in 2.5° increments and can achieve 20 736 unique positions. They feature an embedded controller, capacitive crash protection to prevent probe damage and a hirth gear for highly accurate positioning of the probe.

The probe heads can either be mounted to the CMM with a shank or flange (HH-A version) or directly into the ram of the machine (HH-AS version for 80 mm rams). Laser scanners and scanning probes can be supported further from the axis of rotation (750 mm) than with conventional heads due to the combination of extreme rotational torque and the heavy duty kinematic joint (HDKJ) adapter.

The HDKJ can be changed either manually without the need for requalification or automatically with the HR-R probe changer rack fitted with the optional HR-RH heavy duty module.

	HH-A-H2.5 HDKJ 2.5°	HH-AS8-H2.5 HDKJ 2.5°
Part no. *	03939430	03939431
Indexing angle	2.5°	2.5°
A axis	± 180°	± 180°
B axis	± 180°	± 180°
Total number of positions	20 736	20 736
Rotation speed	90° in 2.5 s	90° in 2.5 s
Positioning repeatability	< 0.5 µm at 100mm from the centre of A axis rotation	< 0.5 µm at 100mm from the centre of A axis rotation
Max recommended drive torque	1.7 Nm	1.7 Nm
Maximum extension length	750 mm	750 mm
Weight	1 550 g	1 600 g
Head mounting	Shank/flange	80 mm ram
Head controller	HH-C-V2.1 / HH-CA-V2.0 (with HR-R probe changer rack)	HH-C-V2.1 / HH-CA-V2.0 (with HR-R probe changer rack)

\* For information about available sets and adapters, please see pages 46 - 47

## Continuous probe head

HH-ACW-43MW

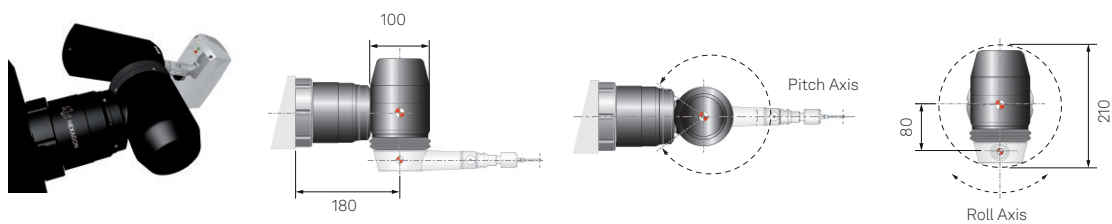

Offering the ultimate in flexibility, the HH-ACW-43MW multi-axis continuous probe head enables fast and accurate orientation of probes in any probing direction in space. Alongside the ability to handle standard extensions up to 600 mm in length, the continuous positioning of rotary axes (in unlimited angular positions) enables complete access to the part being measured.

The exclusive probe changer rack allows for automatic exchange of extensions and adapters, ensuring ideal flexibility. With its multiwire adapter, the HH-ACW-43MW continuous probe head is compatible with the most popular probes and styli/probe changer racks, allowing point-to-point and scanning measurements.

The HH-ACW-3AA can be configured with integrated third axis for optimised use of non-contact sensors.

HH-ACW-43MW	
Part no.	G30481300
Useful angular stroke (Roll axis)	$\pm 180^\circ$
Useful angular stroke (Pitch axis)	$\pm 170^\circ$
Rotation speed	1 rad/sec.
Acceleration	10 rad/sec. <sup>2</sup> / 0.14 arc <sup>ll</sup>
Positioning repeatability	$1 \times 10^{-5}$ rad
Weight	3.5 kg
Max. tool weight	1.5 kg
Max. applied torque	2 Nm
Adapters	HA-ACW-AA, HA-ACW-3AA
Extensions	E200-mw, E330-mw, E570-mw, HP-T-RP, HP-T, HP-TM
Changer racks	HR-ACW-AC, HR-MP



HEXAGON

0 10 20 30 40 50

0 10 20 30 40 50

## Touch trigger probes

### HP-THD

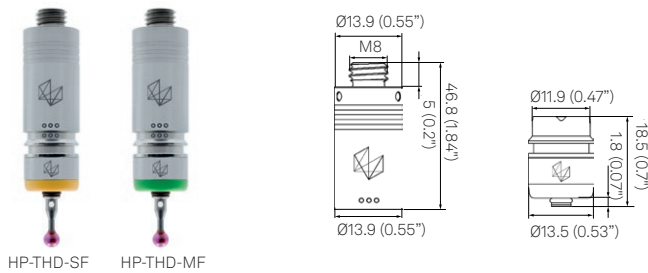

Built from cutting-edge technology, the HP-THD touch trigger probe is particularly well-suited for applications with tight tolerances, as well as tasks that require both high speed measurement and a high level of point density. The HP-THD delivers highly accurate touch trigger probing with styli configurations of up to 100 mm. It offers high-precision repeatability and low 3D form error thanks to a highly innovative optomechanical design capable of detecting nanometric movements in the X, Y and Z directions.

With its robust design and long module life, the HP-THD reduces downtime and enables additional time and cost savings with its high performance and fast stylus and module changes.

Standard probes employ a mechanical switch to create probing points that generate variable force dependant on the direction of probing. This force leads to small form errors sometimes called 'lobing'. The mechanical design of the HP-THD touch trigger probe saves potential rework time by overcoming this force to deliver very low lobing in all six probing directions.

	HP-THD-SF Standard force	HP-THD-MF Medium force	
Touch trigger probes	Part no. (Probe module)	03939603	03939604
	Kit no. (Probe module and body)	03939621	03939622
	Part no. (Probe body)	03939601	03939601
	Part no. (Styli kit)	03969161	03969161
	Overtravel force (XY plane)	Max. 0.3 N	Max. 0.7 N
	Overtravel force (Z plane)	1.2 N	2.6 N
	Mounting	M8 with active 1 wire connection	M8 with active 1 wire connection
	Suitable interface	HH-C-V2.1 or higher	HH-C-V2.1 or higher
	Trigger force (XY plane)	0.07 N	0.07 N
	Trigger force (Z plane)	0.78 N	0.78 N
	Probing directions	6 Way $\pm X$ , $\pm Y$ and $\pm Z$	6 Way $\pm X$ , $\pm Y$ and $\pm Z$
	Form error (2D)	0.8 $\mu\text{m}$	0.8 $\mu\text{m}$
	Form error (3D)	1.3 $\mu\text{m}$	1.3 $\mu\text{m}$
	Unidirectional repeatability $2\sigma^*$	0.3 $\mu\text{m}$	0.3 $\mu\text{m}$
	Weight (probe and body)	21.6 g	21.6 g
	Stylus mounting	M2	M2
	Module changer rack	HR-P / HR-MP	HR-P / HR-MP
	Max. probe head extensions	200 mm (HH-A-M5 or HH-A-M7.5) 300mm (HH-A-T5 or HH-A-T7.5) 450mm (HH-A-T2.5) 750mm (HH-A-H2.5)	200 mm (HH-A-M5 or HH-A-M7.5) 300mm (HH-A-T5 or HH-A-T7.5) 450mm (HH-A-T2.5) 750mm (HH-A-H2.5)
	Max. straight stylus length	30 mm	50 mm (All materials) 100 mm (Mono-block CF)
	Max. star styli length	-	40 mm
Max. star styli extension length	-	20 mm (Mono-block)	
Max. star styli span	-	30 mm (pre-build)	
Weight (Body and Module)	21.6 g	21.6 g	

\* Test conditions: Straight stylus, length 10 mm, touch speed 5 mm/sec.

## Touch trigger probes

### HP-TM



HP-TM is a compact and modular five way touch trigger probe, ideal for fast and high accuracy measurement.

The two piece design comprises of the probe body and a detachable probe module. The body and module are connected together by a highly repeatable kinematic magnetic coupling. The modules can be quickly changed either manually or automatically without the need to recalibrate the probe.

The stylus modules are available in four versions, each giving a different trigger force to ensure high accuracy. The HP-TM system can be easily retrofitted and is compatible with a range of touch trigger controllers, extensions and accessories.

	HP-TM-LF Low force	HP-TM-SF Standard force	HP-TM-MF Medium force	HP-TM-EF Extended force	
Touch trigger probes	Part no. (Probe module)	03939170	03939171	03939172	03939173
	Part no. (Probe body)	03939174	03939174	03939174	03939174
	Pretravel variance	± 0.6 µm	± 0.8 µm	± 1.00 µm	± 2.00 µm
	Trigger force	0.055 N at 10 mm	0.08 N at 10 mm	0.10 N at 25 mm	0.10 N at 50 mm
	Repeatability 1D (2 sigma)*	< 0.35 µm	< 0.35 µm	< 0.5 µm	<0.65 µm
	Probing directions	± X, ± Y, + Z	± X, ± Y, + Z	± X, ± Y, + Z	± X, ± Y, + Z
	Probe mounting	M8	M8	M8	M8
	Stylus mounting	M2	M2	M2	M2
	Max. stylus length	30 mm	50 mm	60 mm	60 mm
Weight (Probe and body)	11 g	11 g	11 g	11 g	

\* Test conditions: Stylus length 10 mm, Touch speed 8 mm/sec.

### Contents of HP-TM Kits

	Kit 1	Kit 2	Kit 3	Kit 4	Kit 5	Kit 6	Kit 7	Kit 8	Kit 9	Kit 10	Kit 11	
HP-TM Kits	Part no.	03939175	03939210	03939211	03939212	03939213	03939214	03939215	03939216	03939217	03939218	03939219
	HP-TM-LF	1 pc.							1 pc.			
	HP-TM-SF	1 pc.	2 pc.	1 pc.	1 pc.					1 pc.		
	HP-TM-MF	1 pc.		1 pc.		2 pc.	1 pc.				1 pc.	
	HP-TM-EF	1 pc.			1 pc.		1 pc.	2 pc.				1 pc.
	HP-TB probe body	1 pc.	1 pc.	1 pc.	1 pc.	1 pc.	1 pc.	1 pc.	1 pc.	1 pc.	1 pc.	1 pc.

## Touch trigger probes

### HP-T



Cost-effective and sturdy, the HP-T touch trigger probe is a durable and compact five way touch trigger probe, offering high accuracy and measuring flexibility.

The HP-T is available in one of four variations, each providing a different trigger force (ranging from low to extended force).

The touch trigger probe is fitted with a M8 threaded connection, enabling compatibility with a wide range of manual and automatic probe heads. A kinematic adapter can also enable automatic module changes with the HR-R changer rack.

	<b>HP-T-LF</b> Low force	<b>HP-T-SF</b> Standard force	<b>HP-T-MF</b> Medium force	<b>HP-T-EF</b> Extended force
<b>Touch trigger probes</b>				
Part no.	03939070	03939071	03939072	03939073
Pre travel variance	± 0.6 µm	± 0.8 µm	± 1.00 µm	± 2.00 µm
Trigger force	0.055 N at 10 mm	0.08 N at 10 mm	0.10 N at 25 mm	0.10 N at 50 mm
Repeatability 1D (2 sigma)*	< 0.35 µm	< 0.35 µm	< 0.5 µm	< 0.65 µm
Probing directions	± X, ± Y, +Z	± X, ± Y, + Z	± X, ± Y, + Z	± X, ± Y, + Z
Probe mounting	M8	M8	M8	M8
Stylus mounting	M2	M2	M2	M2
Max. stylus length	30 mm	50 mm	60 mm	60 mm
Weight	9.5 g	9.5 g	9.5 g	9.5 g

\* Test conditions: Stylus length 10 mm, Touch speed 8mm/s

## Touch trigger probe

### HP-T-RP

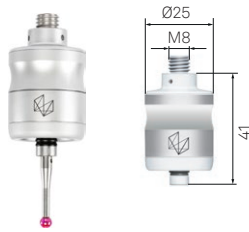

Compatible with all Hexagon bridge and sheet metal measuring machines, the HP-T-RP is a robust and accurate touch trigger probe designed to be used in even the harshest industrial environments.

The rugged nature of the probe makes it ideally suited to work with both robots and portable equipment. The accuracy can be optimised by manually adjusting the trigger force for the required application.

HP-T-RP		
Touch trigger probe	Part no.	03939350
	Probing directions	$\pm X, \pm Y, + Z$
	Stylus force	0.11 N to 0.30 N
	Repeatability 1D (2 sigma)*	0.35 $\mu\text{m}$
	Probe mounting	M8
	Stylus mounting	M3
	Overtravel	X/Y: $\pm 22.0^\circ$ , Z: 5.5 mm (with 0.11 N), 2.0 mm (with 0.30 N)
	Max stylus length	100 mm
	Weight	43 g

\* Test conditions: Stylus length 21 mm, Force setting 0.12 N, Touch speed 8mm/s

## Scanning probes

HP-S-X1S | HP-S-X1H | HP-S-X1C

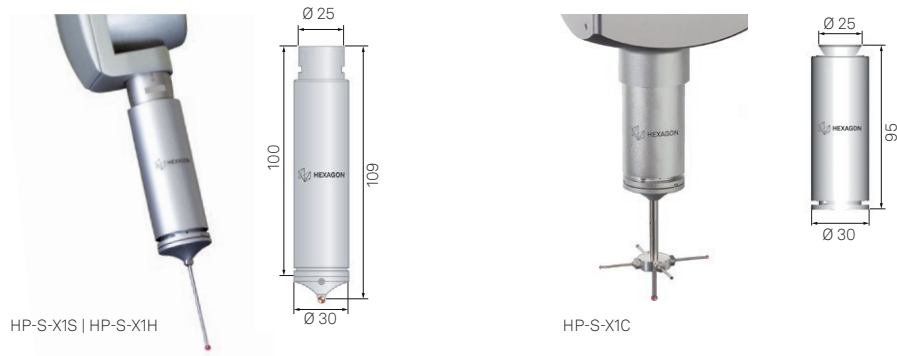

HP-S-X1 are highly accurate 3D scanning probes that can rapidly and automatically collect thousands of data points for the complete and precise evaluation of all part features, including form, location and size.

HP-S-X1 scanning probes support both single point probing and continuous scanning. HP-S-X1 probes provide simultaneous and unclamped probing in all axes, always orthogonal to the contact surface.

The probes' optional self-centring mode are particularly useful for measuring gears.

HP-S-X1S and HP-S-X1H are equipped with a kinematic joint, which allows for automated probe changes with the HR-R probe changer rack. Magnetic stylus holders enable fast and repeatable stylus changes using the HP-S-X styli changer rack or the three port unit of the HR-R probe changer rack.

HP-S-X1C is equipped with a dovetail connector for mounting directly into the ram of the machine.

	HP-S-X1S	HP-S-X1H	HP-S-X1C
Part no.	M00-114-040-000	M00-114-042-000	M00-114-043-000
Probe type	Analogue	Analogue	Analogue
Probe connector	TKJ (kinematic joint)	TKJ (kinematic joint)	Centre mounted
Dimensions	Ø 30 x 109 mm	Ø 30 x 109 mm	Ø 30 x 95 mm
Weight	100 g	100 g	100 g
Resolution	< 0.1 µm	< 0.1 µm	< 0.1 µm
Measuring range	± 2 mm in all axes	± 2 mm in all axes	± 2 mm in all axes
Linear stiffness	1.2 N/mm	1.2 N/mm	1.2 N/mm
Stylus holder thread	M3	M3	M3
Max. stylus weight (Including stylus clamping)	20 g	33 g	33 g
Max. stylus length	Axial: Up to 115 mm Lateral: Up to 20 mm	Axial: Up to 225 mm Lateral: Up to 100 mm	Axial: Up to 225 mm Lateral: Up to 100 mm



## Scanning probe

### HP-S-X3

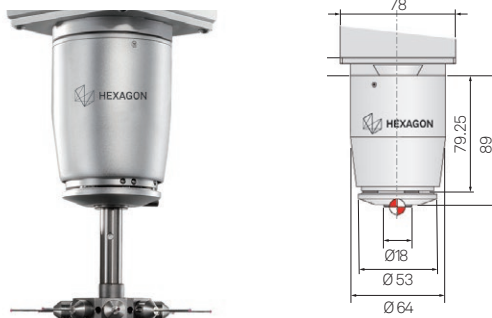

Compact, fast and accurate, the HP-S-X3 offers effective single point probing in all standard metrology tasks as well as continuous high-speed-scanning for form and profile inspection of complex geometric elements (for example, cylinder gears, worm gears, turbine blades, worm screws, and more).

The HP-S-X3's highly sensitive sensor and large linear measuring range ensures excellent precision and extends application possibilities.

HP-S-X3 can carry up to 360 mm long probing extensions. Probe trigger force is measured by high resolution linear variable differential transducers (LVDT), allowing the correct compensation for stylus deflection even when long extensions are fitted and automatic measurement in a direction orthogonal to the part.

HP-S-X3	
Part no.	M00-114-039-000
Probe type	Analogue
Probe interface	TKJ (kinematic Joint)
Dimensions	Ø 64 x 89 mm
Weight	270 g
Resolution	< 0.1 µm
Measuring range	± 1 mm in all axes
Overtravel range	± 1.25 mm in all axes
Linear stiffness	6 N/mm
Stylus joint	M5
Max. stylus weight	150 g (incl. stylus clamping)
Max. stylus length	Up to 360 mm

## Scanning probes

HP-S-X5 | HP-S-X5HD

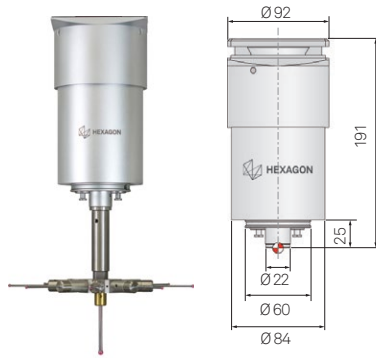

The HP-S-X5 fixed scanning probe is optimised for measuring the tightest of tolerances. Offering very high precision and repeatability, HP-S-X5 enables true 3D probing, capable of simultaneously measuring in the X, Y and Z directions. This analogue probe is well-suited to performing single point probing and continuous high-speed scanning for profile and shape error inspection of complex geometric parts.

The HP-S-X5's motor-free design means there are no heat sources within the probe, helping to ensure results are unaffected by temperature changes. The probe is protected by its robust design and effective anti-collision system, reducing downtime. The probe reduces errors in results with its compensation system that accurately adjusts for the stylus deflection even when long extensions are fitted.

HP-S-X5's dovetail connection allows fast and easy change of the probe when performing maintenance work.

As an option, a workpiece temperature sensor (WTS) can be swapped into the probe automatically.

		HP-S-X5	HP-S-X5HD
<b>Scanning probes</b>	Part no.	M00-114-031-000	M00-114-024-000
	Probe type	Analogue	Analogue
	Position	Centre mounted	Centre mounted
	Probe interface	Dovetail connector	Dovetail connector
	Dimensions	Ø 84 x 191 mm	Ø 84 x 191 mm
	Weight	1 080 g	1 080 g
	Resolution	< 0.1 µm	< 0.1 µm
	Measuring range	± 1 mm in all axes	± 1 mm in all axes
	Overtravel range	± 2 mm in all axes	± 2 mm in all axes
	Linear stiffness	5 N/mm	5 N/mm
	Stylus joint	M5	M5
	Max. stylus weight	500 g (Incl. Stylus clamping)	650 g (Incl. stylus clamping)
	Max. stylus length	Up to 500 mm	Up to 800 mm
	Collision protection	Standard	Standard
	Air supply	0.5 MPa	0.5 MPa
	Part temperature sensor	Optional	Optional
	Profiler R (tactile roughness sensor)	Not compatible	Optional

## Temperature sensor

For HP-S-X5



The exchangeable HP-S-X5 temperature sensor enables fast automatic measurement of workpiece temperature.

By using the various modules available (joints and extensions), users can assemble any configuration necessary to measure temperature, even on inclined surfaces. This allows the sensor to be set up to fulfil the unique requirements of any measuring task.

The sensor can be stored in a rack just like any other stylus configuration and can be loaded automatically within a part program. An integrated electrical interface connects the sensor with the probe head and the electronics of the CMM.

Part temperature sensor for HP-S-X5		
Temperature sensor	M00-741-073-000	Exchangeable temperature sensor basis kit (incl. clamping and sensor), calibrated
	M00-741-079-000	Exchangeable temperatur sensor complete kit (incl. clamping, sensor, joint, extension), calibrated
	M00-741-062-150	Extension
	M00-741-062-050	Joint

# Laser scanners

HP-L-10.6T | HP-L-10.6A | HP-L-20.8T

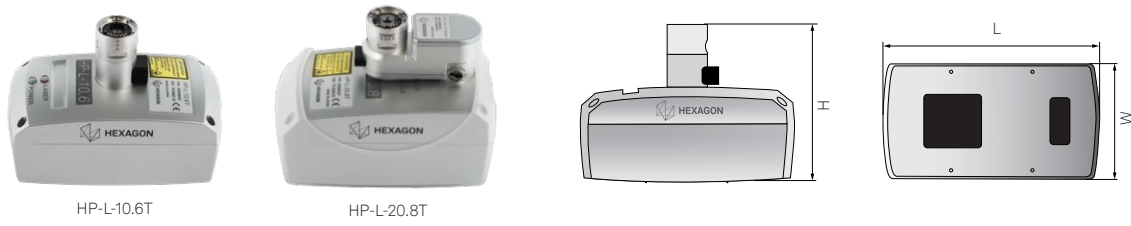

HP-L-10.6 and HP-L-20.8T laser scanning sensors deliver maximum performance for complex surfaces and workpieces made of materials that are difficult to measure. These versatile laser scanners record precisely even at the highest speeds and are particularly well-suited to inspecting the characteristics of thin-walled components, sheet metal parts, freeform surfaces, and reverse engineering. The accuracy of the sensors is certified to the standard ISO 10360-8:2013.

Offering excellent measurement flexibility, the laser line width can be varied as needed from 24 mm to 124 mm (HP-L-10.6) and up to 220 mm (HP-L-20.8). The laser power is automatically adjusted in real time.

The HP-L-10.6T can be used on almost all Hexagon CMMs. HP-L-10.6A and HP-L-20.8T can be used on a CMM with adapters.

**Warming post for HR-R Probe Changer Rack 03939507**

**Manual warm-up station (TKJ) G32438600 / Manual warm-up station (autojoint) G3243800**

**Set of 4 TKJ Angular Adapters (to be used only with HP-L-10.6T) 03969394**

HP-L-20.8T on a CMM the following additional items should be ordered: **HP-LC-210 Controller (P/N 03939534), 1x Power unit 24 VDC with cables (03939505), 1x TKJ key (03969357), 1x HA-C-T Adapter TKJ for HP-L-20.8T (03939526) or 1x HA-C-A Adapter AJ for HP-L-20.8T (03939527), 1x Sphere (03939542)**

	HP-L-10.6T TKJ connection	HP-L-10.6A Autojoint connection	HP-L-20.8T TKJ connection
Part no.	03939500	03939501	03939535
Size L x W x H	134 x 72 x 60 (98) mm	134 x 72 x 60 (87) mm	137 x 76 x 85 mm
Weight	379 g	360 g	410 g
Standoff and depth (Z)	170 ±30 mm	170 ±30 mm	180 ±40 mm
Measuring accuracy ISO 10360-8:2013* (GLOBAL CMMs)			
PForm.Sph.D95%:Tr:ODS (MPL) Probe dispersion value	34 µm	34 µm	36 µm
PForm.Sph.1x25:Tr:ODS (MPE) Probing form error	22 µm	22 µm	25 µm
Lines per second (max.)	53 Hz	53 Hz	100 Hz
Laser line width (at mid-field)	24, 60 or 124 mm	24, 60 or 124 mm	25, 51, 63, 130 or 220 mm
Data rate (max.)	30 000 pts/sec	30 000 pts/sec	150 000 pts/sec
Ambient light of the sensor	40 000 lx	40 000 lx	40 000 lx
Laser protection class	2 ICE 60825-1:2007	2 ICE 60825-1:2007	2 ICE 60825-1:2007
Laser	Visibly red, (690 nm)	Visibly red, (690 nm)	Visibly red, (690 nm)
Operating temperature	+5 to +45°C (41 to 113°F)	+5 to +45°C (41 to 113°F)	+5 to +45°C (41 to 113°F)
Declared accuracy temperature range	+15 to +32°C (59 to 90°F)	+15 to +32°C (59 to 90°F)	+15 to +32°C (59 to 90°F)
Relative humidity	90% non-condensing	90% non-condensing	90% non-condensing
Power supply	All: DC 18 to 28 V, 170 to 200 mA, protected against polarity reversal	All: DC 18 to 28 V, 170 to 200 mA, protected against polarity reversal	All: DC 18 to 28 V, 170 to 200 mA, protected against polarity reversal
Protection against dust and water	All: IP64 (IEC 60529) except for warm-up connection	All: IP64 (IEC 60529) except for warm-up connection	All: IP64 (IEC 60529) except for warm-up connection
Storage temperature	All: -25 to +70 °C (-13 to 158° F)	All: -25 to +70 °C (-13 to 158° F)	All: -25 to +70 °C (-13 to 158° F)
Laser safety			

\* Values include expanded measurement uncertainty according to ISO/TS 17865:2016. Measured using a manufacturer supplied sphere- and plane artefact, each certified by an independent accredited lab.

## Laser scanners

HP-L-5.8T | HP-L-5.8A

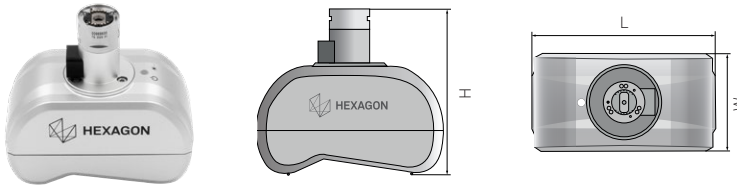

HP-L-5.8T

The HP-L-5.8 laser scanning sensor makes it easy and affordable to begin creating point clouds on a CMM. The fixed-line blue laser can measure a wide range of surfaces, from very dark through to very shiny. The rugged and compact design makes it ideal for laser scanning on smaller CMMs and where accessibility is restricted.

The HP-L-5.8T is equipped with Hexagon’s kinematic joint, making it compatible with Hexagon probe heads and accessories, including automatic sensor changing racks and extensions.

Warming post for HR-R Probe Changer Rack 03939507

Manual warm-up station (TKJ) G32438600 / Manual warm-up station (autojoint) G3243800

Set of 4 TKJ Angular Adapters (to be used only with HP-L-5.8T) 03969394

	HP-L-5.8T TKJ connection	HP-L-5.8A Autojoint connection
Part no.	HP-L-5.8T-SYSTEM	HP-L-5.8A-SYSTEM
Size L x W x H	116 x 62 x 86.5 (106.5) mm	116 x 62 x 81 (101) mm
Weight	380 g	360 g
Standoff and depth (Z)	140 ± 40 mm	140 ± 40 mm
Measuring accuracy ISO 10360-8:2013* (Global CMM except Global extra)		
PForm.Sph.D95%:Tr:ODS (MPL) Probe dispersion value	34 µm	34 µm
PForm.Sph.1x25:Tr:ODS (MPE) Probing form error	22 µm	22 µm
Lines per second (max.)	40 Hz	40 Hz
Laser line width (at mid-field)	47 mm	47 mm
Data rate (max.)	36,000 pts/sec	36,000 pts/sec
Ambient light of the sensor	5 000 lx	5 000 lx
Laser protection class	2 (IEC 60825-1: 2014)	2 (IEC 60825-1: 2014)
Laser	Visible blue - 450 nm	Visible blue - 450 nm
Operating temperature	5 to 45° C (41° to 113°F)	5 to 45° C (41° to 113°F)
Declared accuracy temperature range	15 to 32° C (59° to 90°F)	15 to 32° C (59° to 90°F)
Relative humidity	90% non-condensing	90% non-condensing
Power supply	All: DC 18 to 28 V, 170 to 200 mA, protected against the polarity reversal	All: DC 18 to 28 V, 170 to 200 mA, protected against the polarity reversal
Protection against dust and water	All: IP64 (IEC 60529) (except for warm-up terminal)	All: IP64 (IEC 60529) (except for warm-up terminal)
Storage temperature	All: -25° to +70° C (-13° to +158° F)	All: -25° to +70° C (-13° to +158° F)
Laser safety		

\* Values include expanded measurement uncertainty according to ISO/TS 17865:2016.  
Measured using a manufacturer supplied sphere- and plane artefact, each certified by an independent accredited lab.

## Vision sensor HP-C-VE



The versatile HP-C-VE vision sensor is a general purpose image analysis tool for enhancing the measurement capabilities of a CMM.

The HP-C-VE contains a customisable illumination system, making it a self-contained measuring system, suitable for a wide range of applications. Due to its general-purpose nature, the HP-C-VE sensor uses fixed magnification and is designed for taking data points in a static condition. It provides oblique overhead illumination of the feature being inspected.

The HP-C-VE is compatible with the HR-R probe changer rack. This system allows the CMM to automatically change the sensor being used, enabling the HP-C-VE to be integrated within multiple sensor part programs while removing the need for any operator intervention.

HP-C-VE	
Part no.	CMMV-Set
Field of view (FOV)	Approx. 6 mm x 5 mm (on the work piece being inspected) Area: >35 mm <sup>2</sup>
Optical magnification	The image at the CCD is 75% of the Field of view (FOV) (on the workpiece)
Object to camera standoff	75 mm
Illumination	LED-illuminator Oblique and targeted at the optical plane centre
Type	High intensity green for optimum reflection
Inner LED ring	4 radially spaced at 90° at 0° inclination
Outer LED ring	8 radially spaced at 45° and at 16° inclination (The spacing of these 8 is also staggered radially 22.5° to the 4 LED pattern)
Selective illumination	Rings are split into four segments – intensity of both rings can be adjusted independently

### HP-C-VE Specification according to ISO-10360-7:2011

ISO 10360-7:2011 specifications are valid for the vertical orientation (A0B0 tip)

Acceptance Test	Symbol	Specificaton (µm)
Probing error (with CMM motion)	PF2D,MPE	10.0
Probing error of the imaging probe (without CMM motion)	PFV2D,MPE	6.0
Imaging probe length measurement error (without CMM motion, L in mm)	EUV,MPE	4.0 + 2.0 L

**Optical sensor**  
HP-O FLEX



HP-O delivers excellent speed, precision, and part access. This sensor combines highly accurate interferometric, optical HP-O technology with the flexibility of an automatic indexing probe head, indexing in steps of 2.5° and capable of achieving up to 12 240 unique positions. The probe head offers high speed operation and high rotational torque.

**Optical sensor**  
HP-O HYBRID



This fixed sensor system enables users to combine optical and tactile styli in one configuration. The high precision interferometric, optical HP-O technology offers accuracy and reliability comparable to tactile scanning probes, while also delivering the higher scanning speed, increased measurement range and flexibility of non-contact measurement.

	<p><b>LASER</b> <b>2</b></p>		<p>Laser radiation Do not look into the beam <b>Class 2 Laser Product</b> 620-690 nm / 1 mW cw   1500-1600 nm / 10 mW max. applied standard: IEC 60825-1:2014</p>
--	----------------------------------	--	---

## Probe changer rack HR-ACW-AC

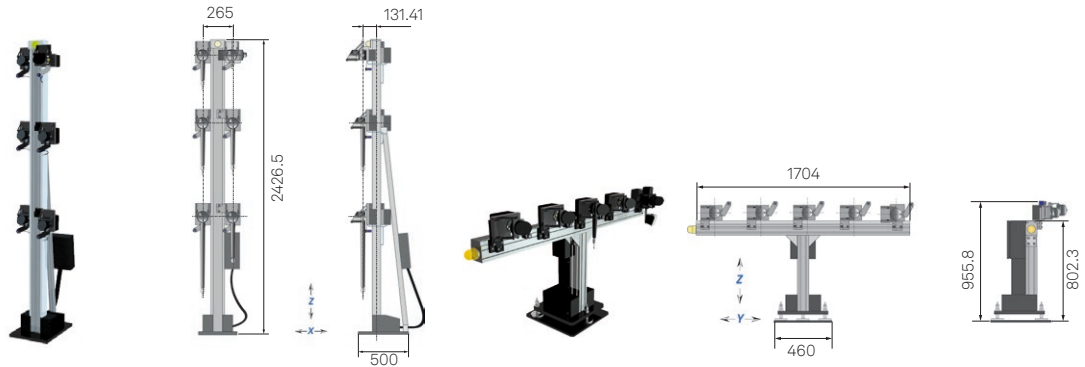

The HR-ACW-AC probe changer rack, in combination with the HH-ACW-43MW probe head, enables automatic repeatable exchange of all Hexagon adapters/extensions during execution of the measuring program. The modular concept of the changer rack allows for configuration of a number of stations.

The rack is available for horizontal or vertical arm CMMs. It can be equipped with a programmable logic controller (PLC), which is used to automatically identify if slots are free or filled.

Changer rack for horizontal arm CMM					
	Part no.	Part description	Weight	Ports	Variation
Horizontal arm CMM	G32631100	Stand of HR-ACW-AC	80 kg	Max. 8	
	G32631201	Station for HH-ACW-43MW adapter and extensions			Without PLC
	G32451600	Station for HH-ACW-3AA adapter with warm up function ARM1			Without PLC
	G32451700	Station for HH-ACW-3AA adapter with warm up function ARM2			Without PLC
	G32435901	Station for HH-ACW-43MW adapter and extensions			With PLC
	G32451200	Station for HH-ACW-3AA adapter with warm up function ARM1			With PLC
	G32451300	Station for HH-ACW-3AA adapter with warm up function ARM2			With PLC

\* Air supply requirements: > 0.45MPa < 1.0MPa (rated working pressure)

Changer rack for vertical arm CMM					
	Part no.	Part description		Ports	Variation
Vertical arm CMM	G32432900	Stand for HR-ACW-AC*		Max. 5	Without PLC
	G32633000	Station for HH-ACW-43MW adapter and Extensions			Without PLC
	G32633100	Station for HH-ACW-3AA adapter with warm up function			Without PLC
	G32436900	Stand for HR-ACW-AC*		Max. 5	With PLC
	G32437300	Station for HH-ACW-43MW adapter and extensions			With PLC
	G32439500	Station for HH-ACW-3AA adapter with warm up function			With PLC

\* Air supply requirements: > 0.45MPa < 1.0MPa (rated working pressure)



## Probe changer rack

HR-R

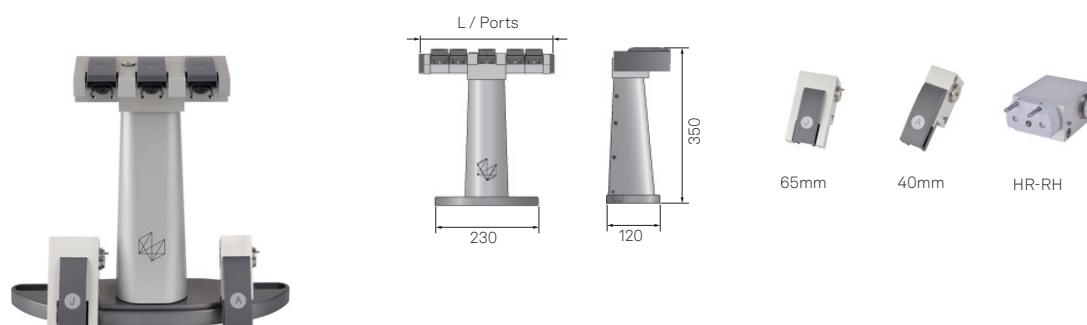

Saving time and increasing flexibility, the HR-R is an automatic probe changer rack that uses Hexagon's unique TKJ connector to exchange probes and extensions to and from the HH-A-T series of probe heads. The probe exchange is performed both quickly and accurately with no need for requalification. The HR-R is modular and can be easily customised to suit any application.

	Part No.	Part description	Ports	L (mm)	H (mm)
Probe changer rack	03939110	HR-R3 with adjustable feet	3	220	350
	03939111	HR-R5 with adjustable feet	5	304	350
	03939112	HR-R9 with adjustable feet	9	472	350
	03939483	HR-MP-A3 + HR-R adapter	Additional 3 ports		
	03939091	HR-RA-40	Additional active port	40	
	03939092	HR-RA-65	Additional active port (for HP-C-VE, HP-L, HP-S-X3T)	65	
	03969370	Rising block			100
	03969371	Rising block			500
	052901	Adjustable feet			
	03939093	HR-RH Module	Module for HA-HT and HA-HM Adapter		
	M00-114-134-000		3 styli exchange ports for HP-S-X1		

## Probe module changer rack

HR-MP

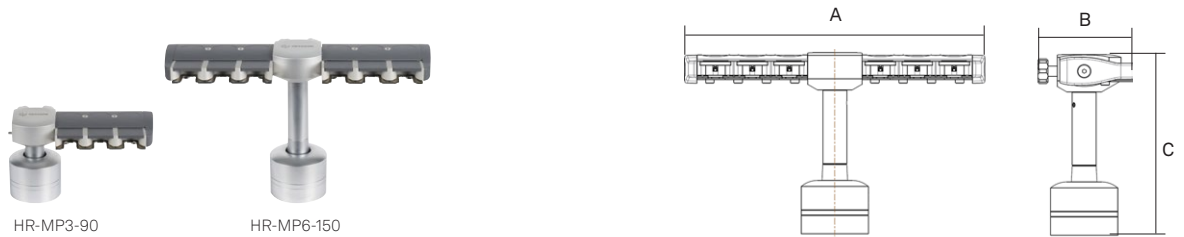

The HR-MP is a passive probe module changer rack that enables the fast interchange of probe modules or styli configuration during measuring cycles, guided directly by the CMM measuring software. Its modular design means it easily adapts to user needs. In addition to carrying between three and six ports, its base can be extended to a maximum height of 250 mm and it is compatible with HP-THD and HP-TM touch trigger probes, as well as HP-S-X1 scanning sensors. The rack can also be removed and placed on machine tables without the need for recalibration.

An optional module can be combined with the HR-R probe changer rack to enable the interchange of equipment without adding an extra rack to the CMM.

	HR-MP3-90	HR-MP6-90	HR-MP6-150
<b>HR-MP Probe Module and Styli Changer Rack</b>			
Part no.	03939480	03939481	03939482
Number of Modules	3 ports	6 ports	6 ports
Height C** (mm)	88	88	148
Width A(mm)	150	245	245
Depth B(mm)	78	78	78
Recommended module change speed	10mm/s		
Max. module changer speed	100mm/s		
Max. entry speed into the rack	800 mm/s		
Crash protection	Yes	Yes	Yes
Overtravel (X- / Y-axis)	20 mm	20 mm	20 mm
Overtravel (Z-axis)	10 mm	10 mm	10 mm
Alignment precision (X- / Y-axis)	± 250µm		
Alignment precision (Z-axis)	± 150µm		

## Styli changer rack for scanning probes HP-S-X1H/S

HR-X1-TR

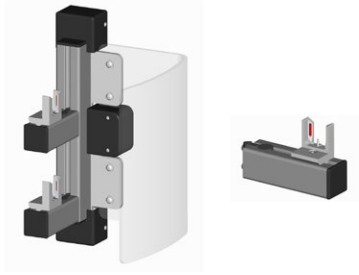

Driving significant cycle time reductions, the HR-X1-TR is attached vertically on the guideway support of the machine and moves with the moving portal of the machine. Unlike a styli changer rack fixed to the base of the machine, the measurement volume isn't reduced with this vertical rack.

The HR-X1-TR can be used together with HP-S-X1S or HP-S-X1H scanning probes. The HR-X1-TR is available with different sizes of magazine strips.

	Part no.	Part description	Z-axis	Max. ports
Racks	M00-398-201-000	HR-X1-TR	300	2
	M00-295-201-000		600	4
	M00-304-201-000		700	4
	M00-304-201-000		900	5
	M00-304-201-200	Styli port		
	M00-398-201-200	Styli port for machine 543		

## Styli changer rack for scanning probes HP-S-X1C/H/S and HP-S-X3

HR-X



The styli changer rack HR-X saves time and reduces manual interventions by enabling quick changes of styli configurations within a measuring program. The HR-X is suitable for Hexagon Reference and GLOBAL coordinate measuring machines in a range of sizes. Depending on probe and the conditions, there are different ports available.

	Part no.	Size CMM	Width (mm)	Height (mm)	Compatibility		
					HP-S-X1H HP-S-X1S	HP-S-X1C	HP-S-X3
Racks	M00-1087-010-000	5.4.3	400	195	✓	(✓)	-
	M00-1087-012-000	5.4.3	400	295	-	✓	✓
	M00-1087-015-000	7.5.5	400	295	✓	✓	✓
	M00-1087-020-000	7.7.5	700	295	✓	✓	(✓)
	M00-1087-022-000	7.7.5	700	395	(✓)	(✓)	✓
	M00-1087-020-000	10.7.6	700	295	✓	✓	(✓)
	M00-1087-022-000	10.7.6	700	395	(✓)	(✓)	✓
	M00-1087-030-000	15.9.7	900	295	✓	✓	(✓)
	M00-1087-032-000	15.9.7	900	395	(✓)	(✓)	✓
	M00-1087-035-000	20.9.7	900	295	✓	✓	(✓)
	M00-1087-037-000	20.9.7	900	395	(✓)	(✓)	✓
	M00-1087-040-000	xx.12.10	1200	395	✓	✓	✓

(✓) represents an alternatively selectable stylus rack

Stylus changer ports or stylus clamping/holders are not included in any styli changer rack and have to be ordered additionally.

## Styli changer rack ports for HP-S-X1 and HP-S-X3

HR-X



M00-114-113-000  
Styli port

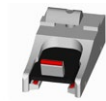

M00-114-167-000  
Styli port shopfloor

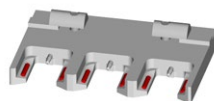

M00-114-213-000 Styli  
port triple



M00-114-109-000  
Styli receptacle

Depending on the size of the scanning probe and the ambient conditions, there are different ports for the styli changer rack HR-X.

	Max. styli changer ports	HP-X1-P	HP-X1-P-SF	HP-X1-3P	HP-X3-P
	Part no.	M00-114-113-000	M00-114-167-000	M00-114-213-000	M00-114-109-000
Styli changer rack ports	M00-1087-010-000	9	9	3	-
	M00-1087-012-000	9	9	3	6
	M00-1087-015-000	9	9	3	5
	M00-1087-020-000	17	17	5	9
	M00-1087-022-000	17	17	5	9
	M00-1087-030-000	22	22	7	12
	M00-1087-032-000	22	22	7	12
	M00-1087-035-000	22	22	7	12
	M00-1087-037-000	22	22	7	12
	M00-1087-040-000	29	29	9	17

## Styli changer rack and extension rack for scanning probe HP-S-X5

HR-XS | HR-XS-EX



The styli changer rack HR-XS (main rack) allows for fast change of styli configurations within a measuring program. The styli changer rack HR-XS is suitable for Hexagon Reference and GLOBAL coordinate measuring machines (depending on the size of the CMM).

Increasing measuring flexibility, the HR-XS-EX extension rack allows for an additional three ports. An already installed styli changer rack HR-XS is required for the use of the extension rack.

	HR-XS Main rack	HR-XS-EX Extension rack	Size CMM Reference / GLOBAL CMMs
<b>Racks</b>	M00-1087-110-000	M00-1087-115-000	10.76
	M00-1087-120-000	M00-1087-125-000	15.9.7
	M00-1087-130-000	M00-1087-135-000	20.9.7
	M00-1087-140-000	M00-1087-145-000	xx.12.10

## Styli changer rack ports

HR-XS -P | HR-XS-P-X



M00-153-285-000



M00-153-286-000

Different styli ports can be used for the HR-XS styli changer rack to cater for different scanning probes and the user's desired position for the styli changer rack.

	Scanning probe HP-S-X5	Size CMM		HR-XS-P	HR-XS-P-X
		Width (mm)	Hight (mm)	M00-153-285-000	M00-153-286-000
<b>Styli changer rack ports</b>				Max. stylus changer ports Styli receptacle in Y	Styli receptacle in X
	M00-1087-110-000	700	415	8	6
	M00-1087-115-000	700	155	8	-
	M00-1087-120-000	900	515	11	8
	M00-1087-125-000	900	155	11	-
	M00-1087-130-000	900	515	11	8
	M00-1087-135-000	900	155	11	-
	M00-1087-140-000	1200	515	14	10
M00-1087-040-000	1200	155	14	-	

## 3rd axis adapter HH-ACW-3AA

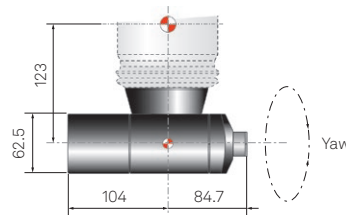
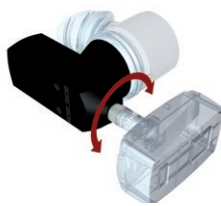

The HA-ACW-3AA 3rd axis adapter allows for the correct application of non-contact sensors in combination with the HH-ACW-43MW. Driving high speed operation, the repeatable docking capability allows the adapter to change both manually or in automatic mode by using the HR-ACW-AC probe changer rack.

HA-ACW-3AA		
3rd axis adapter	Part No.	G30414900
	Useful angular stroke	± 180°
	Rotation speed	1 rad/sec.
	Acceleration	10 rad/sec.
	Resolution	3.16 arc
	Positioning repeatability	7 x 10 rad
	Weight	1.7 Kg
	Max. tool weight	1 kg
	Max. applied torque	1.5 Nm
	Probe changer rack	HR-ACW-A0
Compatible sensors	HP-L	

## Adapter HA-ACW-AA Extensions HA-ACW200M/330M/570M

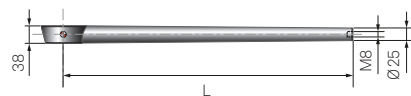
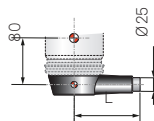

Maximising measurement versatility, the HA-ACW-AA adapter enables the use of all Hexagon probes/extensions equipped with an autojoint connection. The repeatable docking allows users to change the adapter in automatic mode or manual mode by using the HA-ACW-AC probe changer rack.

The series of extensions – available in three different lengths – can be used with all point-to-point probes equipped with an M8 thread. The repeatable docking system allows for automatic and manual change of extensions.

	HA-ACW	Part No.	Material	L (mm)	Weight (g)
Adapter Extensions	HA-ACW-AA (Adapter)	G32026300	Aluminium alloy / Carbon fibre	129.5	500
	HA-ACW-200M (Extension)	G32005800	Aluminium alloy / Carbon fibre	200	500
	HA-ACW-330M (Extension)	G32005900	Aluminium alloy / Carbon fibre	320	600
	HA-ACW-570M (Extension)	G32026000	Aluminium alloy / Carbon fibre	570	650
	Extension Kit	G32026200			

## TKJ to M8 adapters

HA-TM

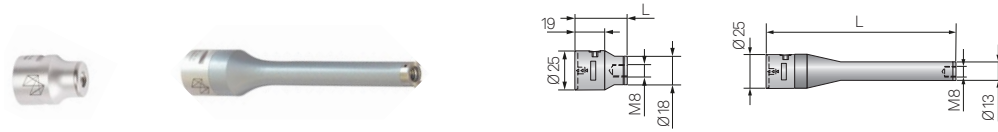

The HA-TM adapters, available in four different lengths, are suitable for all Hexagon touch-trigger probes with M8 threads. The TKJ to M8 adapters allows fast and repeatable probe mounting and dismounting in automatic mode in combination with the HR-R probe changer rack. Changing the probes manually is also possible.

TKJ to M8 adapters	Part No.	Material	L (mm)	Weight (g)
HA-TM-31	03969365	Aluminium / Stainless steel	33	64
HA-TM-140	03969366	Aluminium / Stainless steel	140	84
HA-TM-300	03969367	Aluminium / Stainless steel	300	121
HA-TM-450C	03969368	Carbon fibre / Stainless steel	450	150

## Fixed adapter

HA-F



The HA-F fixed adapter allows any autojoint multiwire probe to be used with the HH-A-T and HH-AS-T probe head series. The HA-F is fully compatible with the HR-R probe changer rack.

Fixed adapter	Part No.	Material	L (mm)	Weight (g)
HA-F	03969369	Stainless steel	35	75

## TKJ extensions and angular adapters

HA-TT

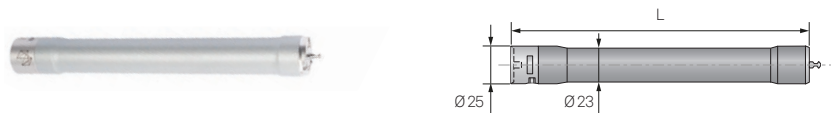

The HA-TT series is a range of extensions and TKJ to TKJ angular adapters. The extensions allow for the use of long stable probe builds for deep measuring applications. The range also contains four angular adapters that enable the probing product to be mounted at a variety of angles. Each adapter contains a full multiwire and is fully compatible with the HR-R probe changer rack.

HA-TT	Part No.	Material	L (mm)	Weight (g)	Angular °
HA-TT-50 Extension	03969360	Aluminium / Stainless steel	52	80	
HA-TT-100 Extension	03969361	Aluminium / Stainless steel	102	102	
HA-TT-200 Extension	03969362	Aluminium / Stainless steel	202	153	
HA-TT-300 Extension	03969363	Aluminium / Stainless steel	302	200	
HA-TT-300C Extension	03969364	Carbon fibre / Stainless steel	302	-	
HA-TT-A0 Angular Adapter	03969390	Aluminium / Stainless steel	35	71	0°
HA-TT-A30 Angular Adapter	03969391	Aluminium / Stainless steel	35	71	30°
HA-TT-A60 Angular Adapter	03969392	Aluminium / Stainless steel	35	71	60°
HA-TT-A90 Angular Adapter	03969393	Aluminium / Stainless steel	35	71	90°
Set of 4 TKJ Angular Adapters	03969394				

## M8 extensions

HA-M

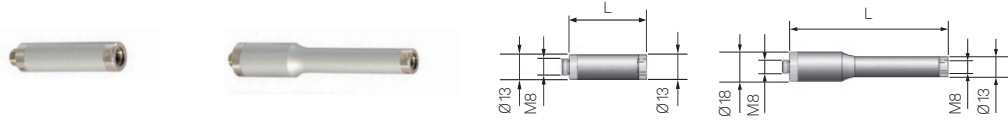

The HA-M series is a range of M8 to M8 threaded connectors enabling deep part access. The extension can be mounted on the HH-MI-M, HH-A-M or HA-TM series of probe heads or accessories. The extensions are available in three sizes: 50, 100 and 200 mm. A HA-M KIT includes all three lengths.

	HA-M	Part No.	Material	L (mm)	Weight (g)
<b>M8 extensions</b>	HA-M KIT	03969077	Aluminium		
	HA-M-50	03969065	Aluminium	50	23
	HA-M-100	03969066	Aluminium	100	55
	HA-M-200	03969067	Aluminium	200	85

## HDKJ to TKJ adapters

HA-HT

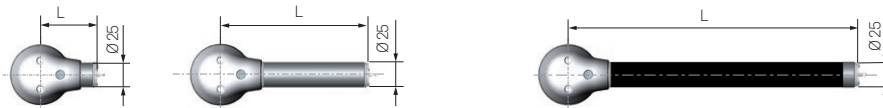

The HA-HT series is a range of HDKJ to TKJ adapters, enabling the use of long stable probe builds for deep measuring applications. Each adapter contains a full multiwire and is fully compatible with the HR-R probe changer rack equipped with a HR-RH module.

	HA-HT	Part No.	Material	L (mm)	Weight (g)
<b>Adapters</b>	HA-HT-CA	03969345	Aluminium	58	170
	HA-HT-150	03969346	Aluminium	150	220
	HA-HT-300C	03969347	Carbon fibre	300	260

## HDKJ to M8 adapters

HA-HM

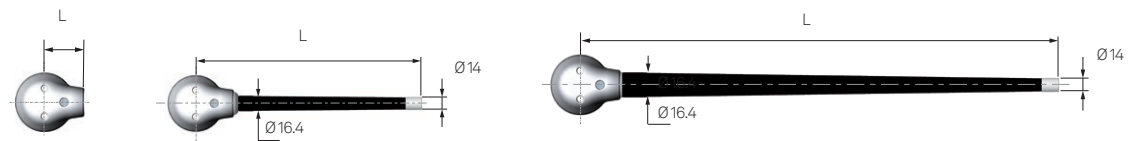

The HA-HM series is a range of HDKJ to M8 adapters, compatible with any touch trigger probe fitted with an M8 connector. HA-HM adapters allow for the use of extremely long and stable probe builds for very deep measuring applications. The adapter is fully compatible with the HR-R probe changer rack equipped with a HR-RH module.

	HA-HM	Part No.	Material	L (mm)	Weight (g)
<b>Adapters</b>	HA-HM-CA	03969395	Aluminium	44,5	170
	HA-HM-250C	03969396	Carbon fibre	250	200
	HA-HM-500C	03969397	Carbon fibre	500	250
	HA-HM-750C	03969398	Carbon fibre	750	300



### Additional styli ports



060-691.492-000  
\*Receptacle PMM  
Weight: 240 g



M00-114-112-000  
\*Receptacle



M00-114-111-000  
\*Receptacle

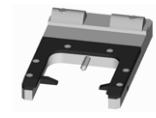

M00-114-110-000  
\*Receptacle

\* not compatible with stylus racks HR-X, HR-XS, HR-XS-EX

### Reference spheres

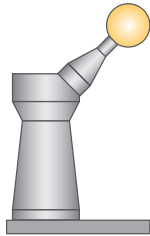

M00-153-270-000, M8  
Ceramic, with stand,  
Ø 30 mm



M00-153-271-000, M8  
Ceramic, without stand,  
Ø 30 mm



M00-398-270-000  
Ceramic, with stand,  
Ø 15 mm, M4

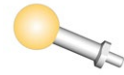

M00-689-364-000  
Ceramic, without stand,  
Ø 25 mm, M6

M00-314-270-000,  
Ceramic, with stand,  
Ø 30 mm, M8  
for Leitz Infinity

M00-398-271-000  
Ceramic, without  
stand, Ø 15 mm, M4



060-694.021-011  
Tommy bar 100 x 3 mm



M07-S02-000-012  
Chamois leather

# Automatic probe heads

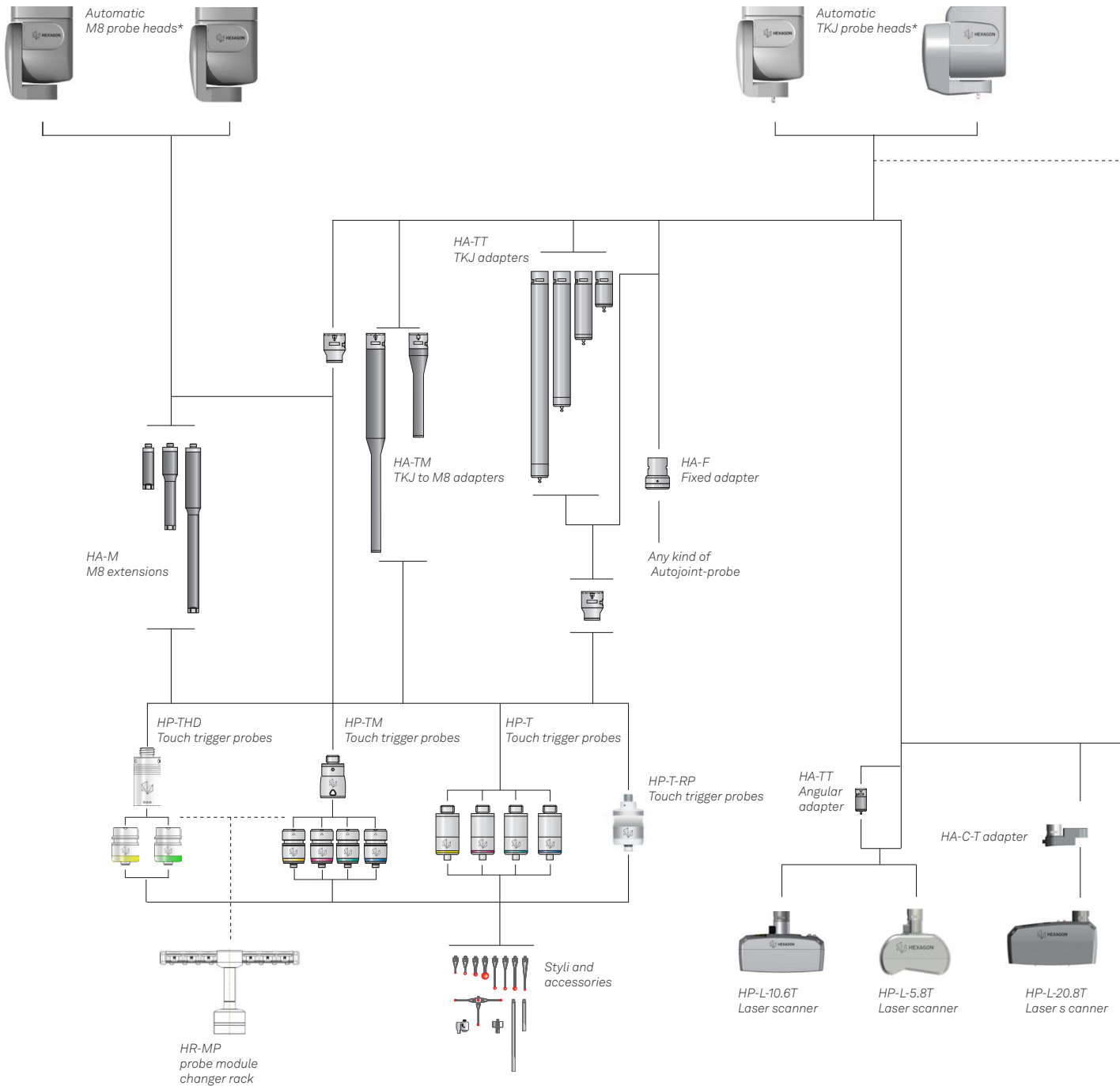

\* To ensure compatibility with the system, please check individual machine configuration or data sheet.

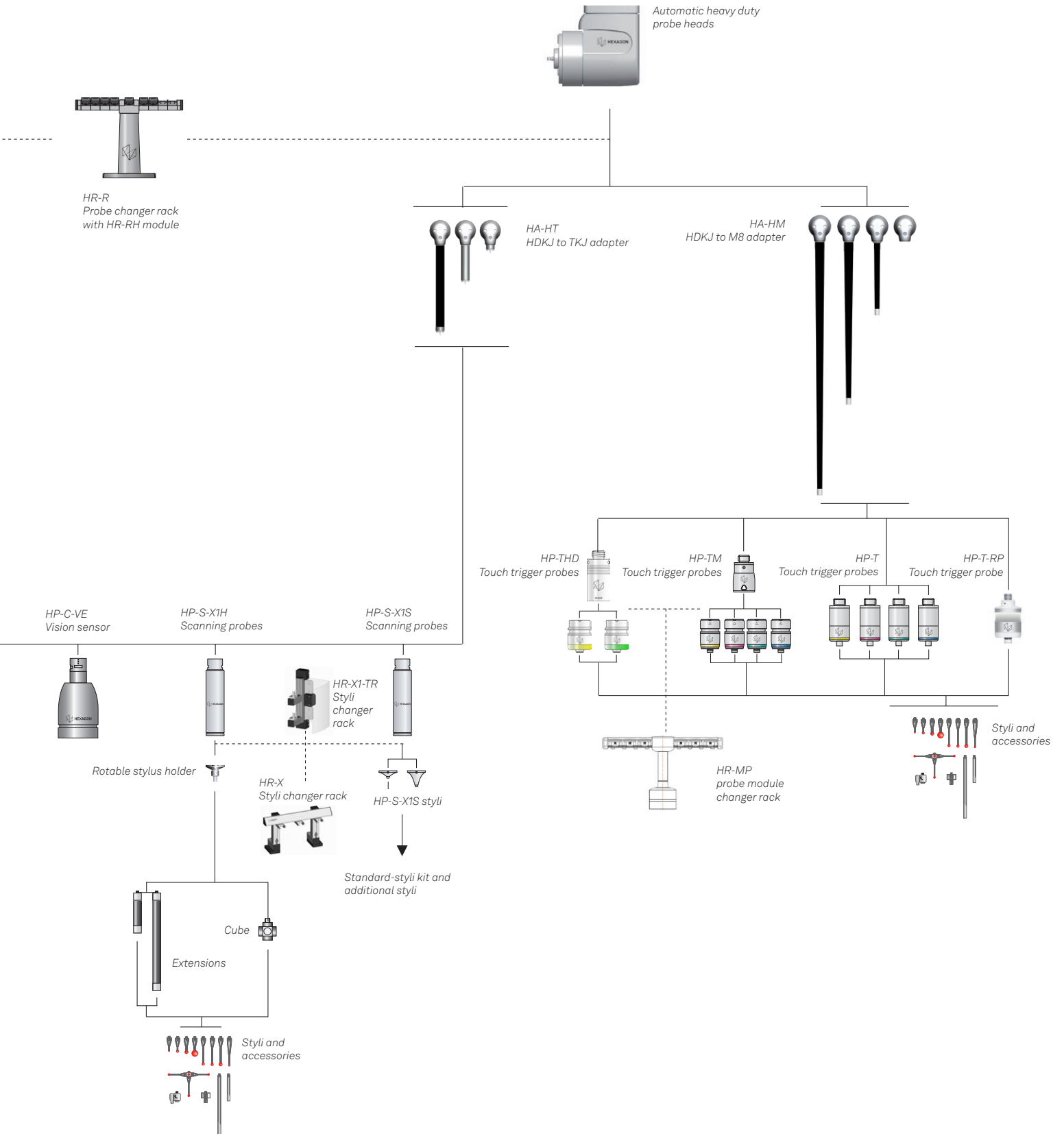

# Continuous probe heads

HH-ACW-43MW

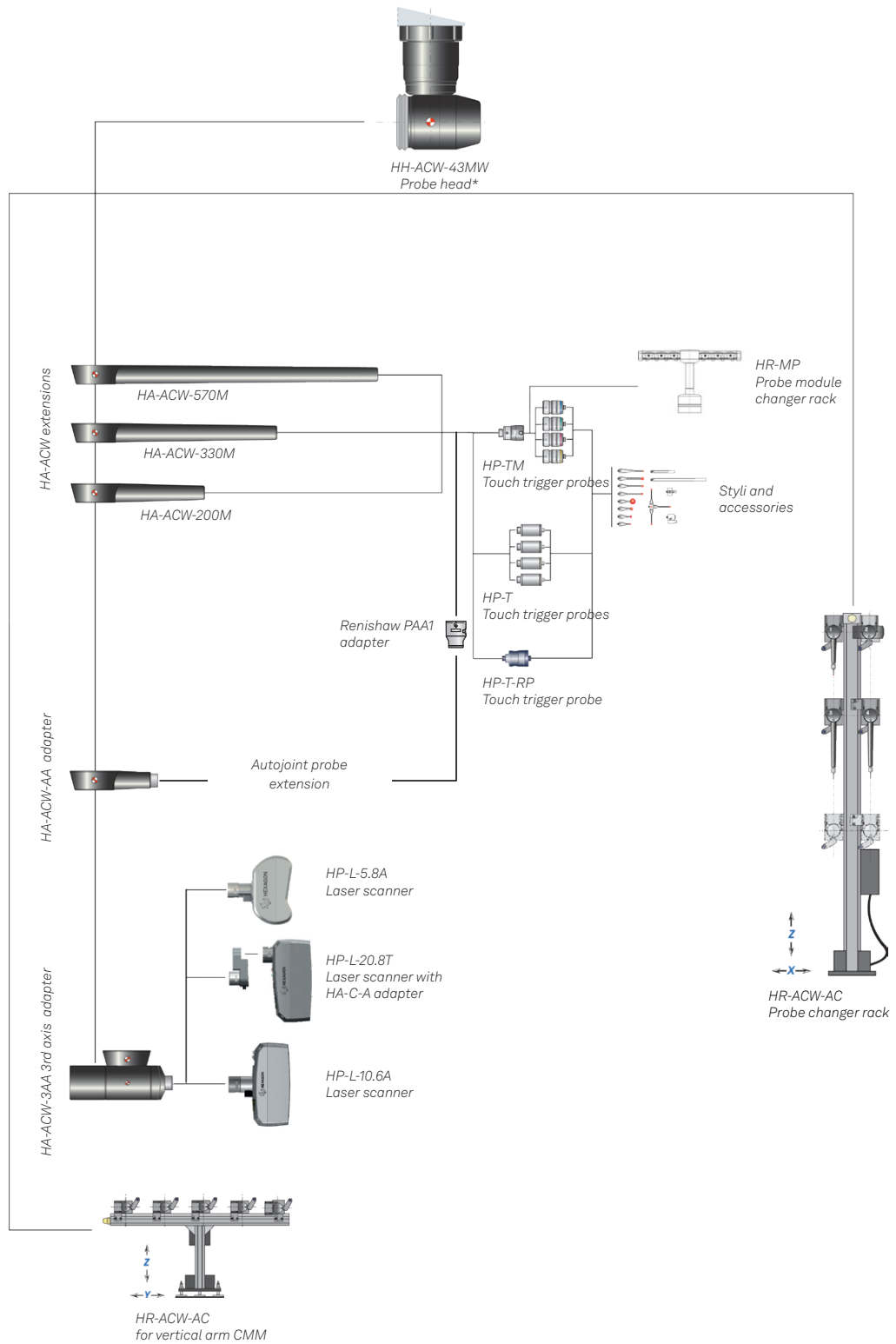

\* To ensure compatibility with the system, please check individual machine configuration or data sheet.

## Scanning probes

HP-S-X1C | HP-S-X3 | HP-S-X5

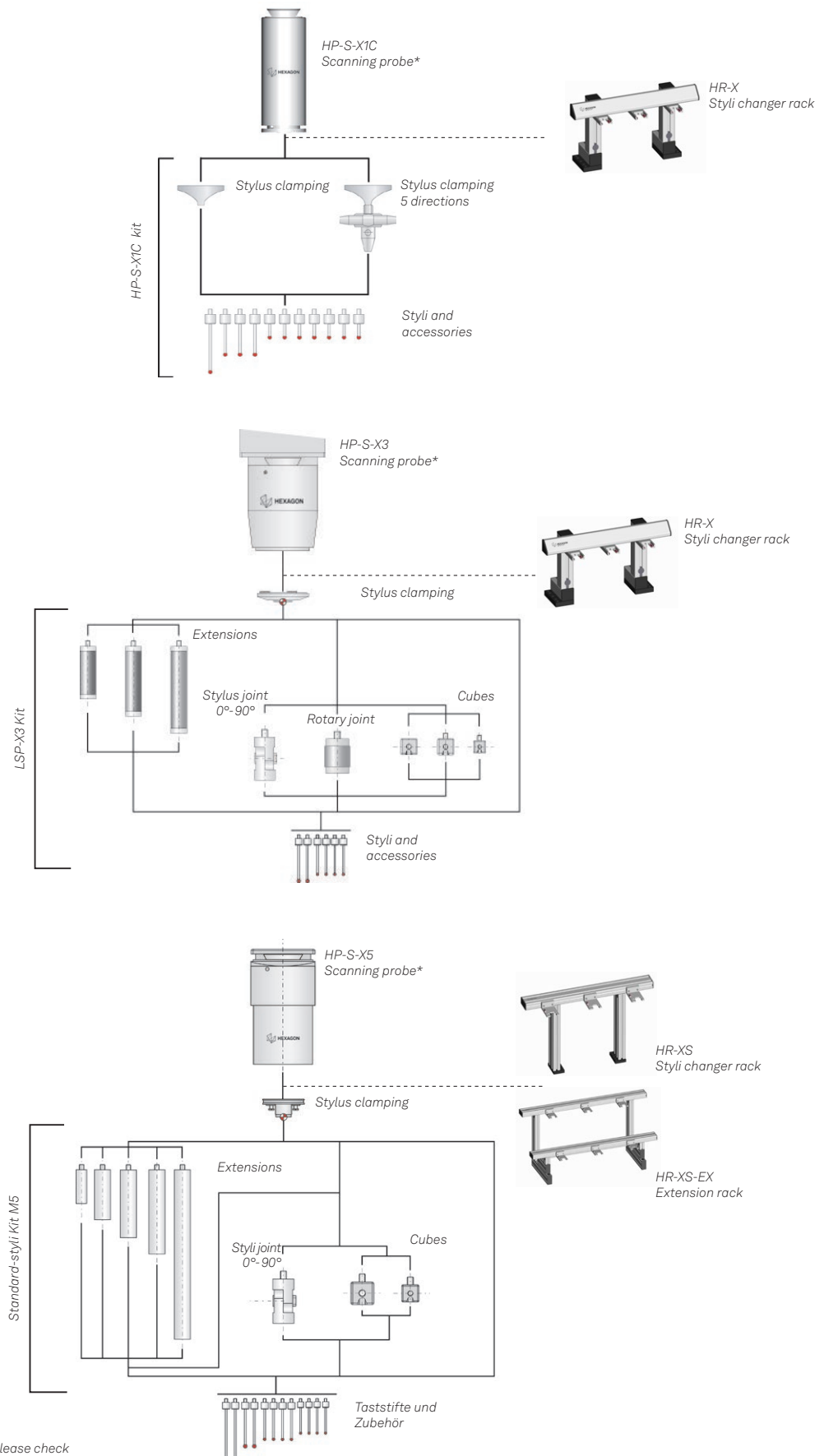

\* To ensure compatibility with the system, please check individual machine configuration or data sheet.

## HH-T

Contents of sets

		047714	Ø9,5mm shaft	DIN 5 pin connection	Sub-D HD 15 pin connection	Sub-D 15 pin connection	LEMO 14 pin connection	M3 stylus 2 x 21mm	M3 stylus 3 x 21mm	M3 stylus 4 x 21mm	M3 extension L10mm	M3 extension L20mm	Star stylus holder
			Built-in	Built-in	Built-in	Built-in	Built-in	03969302	03969303	03969304	03969044	03969045	03969046
HH-T	03939019		1 pc.					1 pc.					
	03939020	1 pc.	1 pc.					1 pc.					
	03939021	1 pc.	1 pc.					1 pc.	1 pc.	1 pc.	1 pc.	1 pc.	1 pc.
	03939024	1 pc.					1 pc.	1 pc.					
	03939025	1 pc.			1 pc.			1 pc.					
	03939027	1 pc.		1 pc.				1 pc.					

## HH-MI

Contents of sets and optional accessories

			Cable DIN 5 pin	M3 stylus 4 x 21mm	D20mm shaft adapter	Cable DIN-DIN	Cable Sub-D 15 pin	Cable Sub-D, 15 pin HD
			03969071	03969304	051555	03969071	03969073	03969074
HH-MI	HH-MI	03939030	1 pc.	1 pc.		Optional	Optional	Optional
	HH-MI	03939103	1 pc.	1 pc.	1 pc.	Optional	Optional	Optional
	HH-MI-M	03939031	1 pc.			Optional	Optional	Optional

## HH-AS

Available adapters and optional accessories

			Sub-D15 pin	Adapter Sub-D HD15 pin Sheffield	Adapter LEMO 14 pin L300mm	Adapter Sub-D HD15 pin
			Built-in	03960289	03960290	03960291
HH-AS	HH-AS8-T5	03939270	1 pc.	Optional	Optional	Optional
	HH-AS6-T5	03939260	1 pc.	Optional	Optional	Optional
	HH-AS8-T7.5	03939362	1 pc.	Optional	Optional	Optional
	HH-AS8-T2.5	03939422	1 pc.	Optional	Optional	Optional
	HH-AS8-H2.5	03939431	1 pc.	Optional	Optional	Optional
	HH-AS8-M5	03939290	1 pc.	Optional	Optional	Optional
	HH-AS6-M5	03939280	1 pc.	Optional	Optional	Optional
	HH-AS8-M7.5	03939363	1 pc.	Optional	Optional	Optional

**HH-A**

Contents of sets

		Flange HH-A to DEA 03939382	Flange HH-A-2.5 to DEA 03939383	Ø 9.5mm shank for HH-A 03939370	Ø 20mm shank for HH-A 03939371	Ø 12mm shank for HH-A 03939372	Sub-D HD 15 Pin 03939065	Sub-D 15 pin 03939066	LEMO 14 pin 03939067	Sub-D HD 15 pin Sheffield 03939068	LEMO 14 pin L300mm 03939069	Probe head
HH-A-T5 - Set 1	03939450											1 pc.
HH-A-T5 - Set 2	03939051			1 pc.			1 pc.					1 pc.
HH-A-T5 - Set 3	03939052				1 pc.			1 pc.				1 pc.
HH-A-T5 - Set 4	03939053							1 pc.				1 pc.
HH-A-T5 - Set 5	03939054			1 pc.				1 pc.				1 pc.
HH-A-T5 - Set 6	03939055	1 pc.						1 pc.				1 pc.
HH-A-T5 - Set 7	03939056			1 pc.						1 pc.		1 pc.
HH-A-T5 - Set 8	03939057	1 pc.								1 pc.		1 pc.
HH-A-T5 - Set 9	03939059					1 pc.					1 pc.	1 pc.
HH-A-M5 - Set 1	03939400											1 pc.
HH-A-M5 - Set 2	03939201			1 pc.			1 pc.					1 pc.
HH-A-M5 - Set 3	03939202			1 pc.				1 pc.				1 pc.
HH-A-M5 - Set 4	03939203	1 pc.							1 pc.			1 pc.
HH-A-M5 - Set 5	03939205	1 pc.						1 pc.				1 pc.
HH-A-T7.5 - Set 1	03939360											1 pc.
HH-A-T7.5 - Set 2	03939365			1 pc.			1 pc.					1 pc.
HH-A-T7.5 - Set 3	03939366			1 pc.				1 pc.				1 pc.
HH-A-T7.5 - Set 4	03939367			1 pc.						1 pc.		1 pc.
HH-A-T7.5 - Set 5	03939368	1 pc.						1 pc.				1 pc.
HH-A-M7.5 - Set 1	03939361											1 pc.
HH-A-M7.5 - Set 2	03939375			1 pc.			1 pc.					1 pc.
HH-A-M7.5 - Set 3	03939376			1 pc.				1 pc.				1 pc.
HH-A-M7.5 - Set 4	03939377			1 pc.						1 pc.		1 pc.
HH-A-M7.5 - Set 5	03939378	1 pc.						1 pc.				1 pc.
HH-A-T2.5	03939420	Cables and shanks sold separately										
HH-A-H2.5	03939430	Cables and shanks sold separately										



Hexagon ist ein weltweit führender Anbieter von Sensor-, Software- und autonomen Lösungen. Wir nutzen Daten, um die Effizienz, Produktivität und Qualität für Anwendungen in der industriellen Fertigung und in den Bereichen Infrastruktur, Sicherheit und Mobilität zu steigern.

Mit unseren Technologien gestalten wir zunehmend stärker vernetzte und autonome Ökosysteme im urbanen Umfeld und in der Fertigung und sorgen so für Skalierbarkeit und Nachhaltigkeit in der Zukunft.

Der Geschäftsbereich Manufacturing Intelligence von Hexagon nutzt Daten aus Design und Engineering, Fertigung und Messtechnik als Basis für Lösungen zur Optimierung von Fertigungsprozessen. Weitere Informationen erhalten Sie auf [hexagonmi.com](https://hexagonmi.com).

Erfahren Sie mehr über Hexagon (Nasdaq Stockholm: HEXA B) unter [hexagon.com](https://hexagon.com). Folgen Sie uns auch auf [@HexagonAB](https://twitter.com/HexagonAB).